

C2 CRAB PLAN TEAM REPORT

MAY 4-7, 2020

KATIE PALOF & MARTIN DORN, JUNE 2, 2020



BSAI CRAB STOCKS MANAGEMENT TIMING

Aleutian Islands golden king crab
Pribilof Islands blue king crab *
Pribilof Islands golden king crab *
Western Aleutian Islands (Adak) red king crab *

Assessed in
May/June

Triennial cycle, next
assessment in 2020

EBS snow crab
Bristol Bay red king crab
EBS Tanner crab
Pribilof Islands red king crab *
St. Matthew blue king crab

Assessed in September/
October

Biennial cycle, next
assessment in 2021

Norton Sound red king crab

Assessed in January/
February



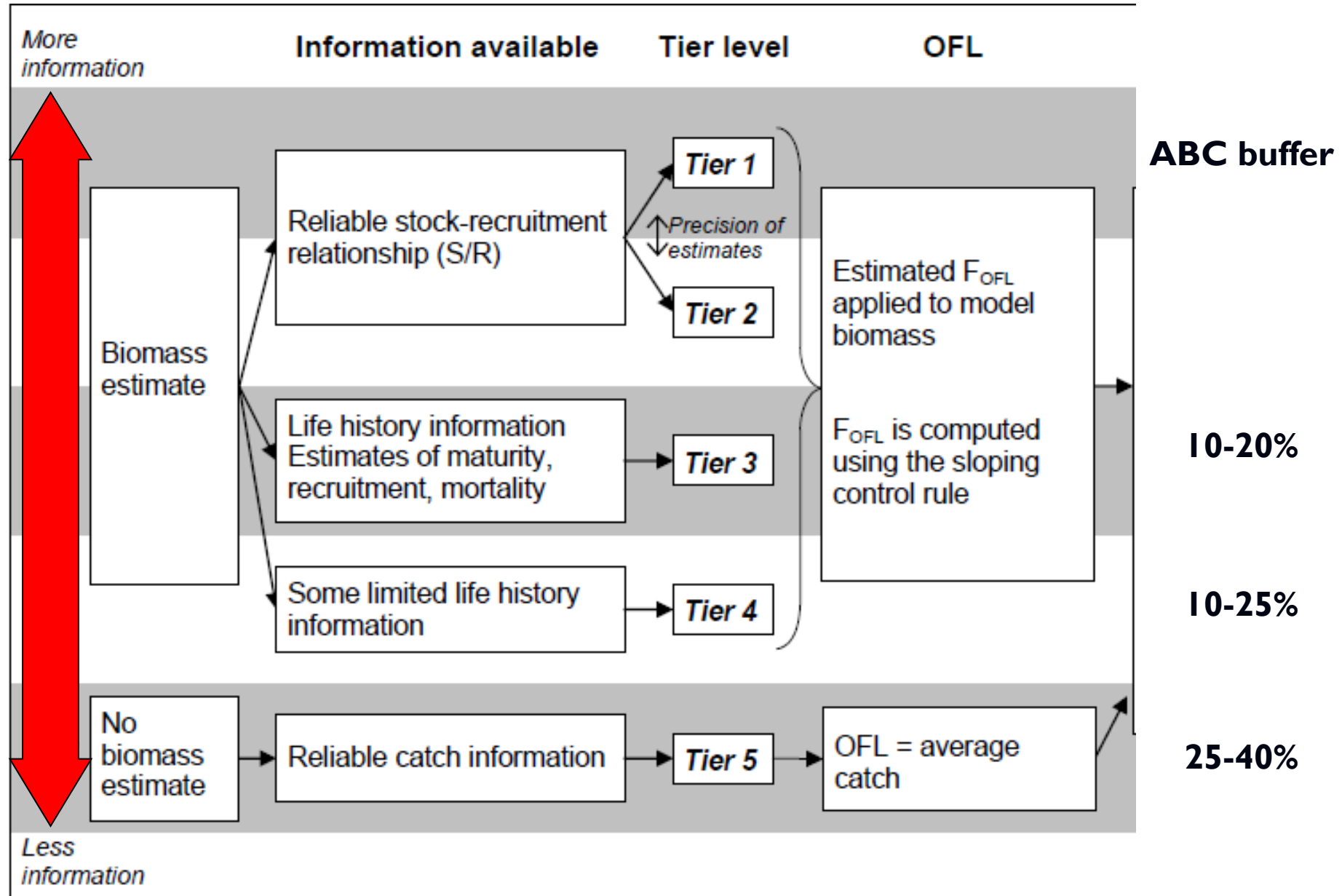

AGENDA

- **Final Assessments (OFL and ABC) for:**
 - **AIGKC**
 - **WAIRKC**
 - **PIGKC**
- Survey updates for 2020
- VAST model for crab data
- BSFRF survey selectivity work
- Model runs for Sept:
 - BBRKC
 - Tanner crab / BOF update
 - Snow crab
 - SMBKC
- Draft ESP for BBRKC
- Climate change and LT/TK for NSRKC
- Other agenda items



ALEUTIAN ISLAND GOLDEN KING CRAB: LENGTH BASED MODELING APPROACH



- Integrated male-only length-based models fitted to fishery dependent catch, CPUE, and tagging data.
- *Constant M* of 0.2 yr^{-1} .
- Projected the abundance from unfished equilibrium in 1960 to initialize the 1985 abundance.
- 6 models for **EAG** and 3 models for **WAG**.
- Specific focus of these models was:
 - CPUE: standardize using negative binomial
 - Year:Area interaction of observer CPUE data
 - Cooperative survey CPUE: include as an additional index in the model
 - Time period used to calculate mean recruitment



Fig. C5. Comparison of cooperative survey CPUE indices (green) and model 20_I CPUE indices (red). The confidence limits are determined with $\pm 2SE$.

COMPARISON OF COOPERATIVE SURVEY AND MODEL CPUE INDICES

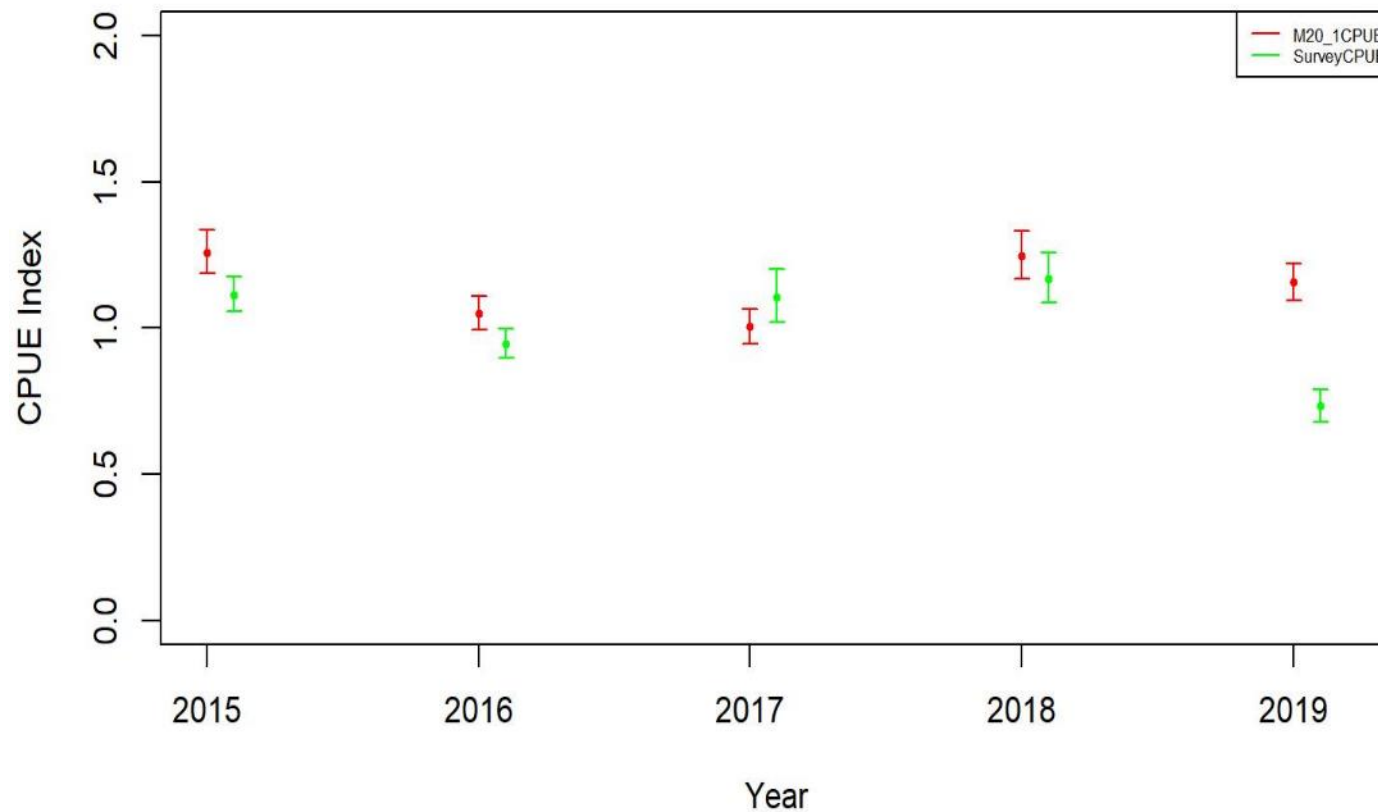
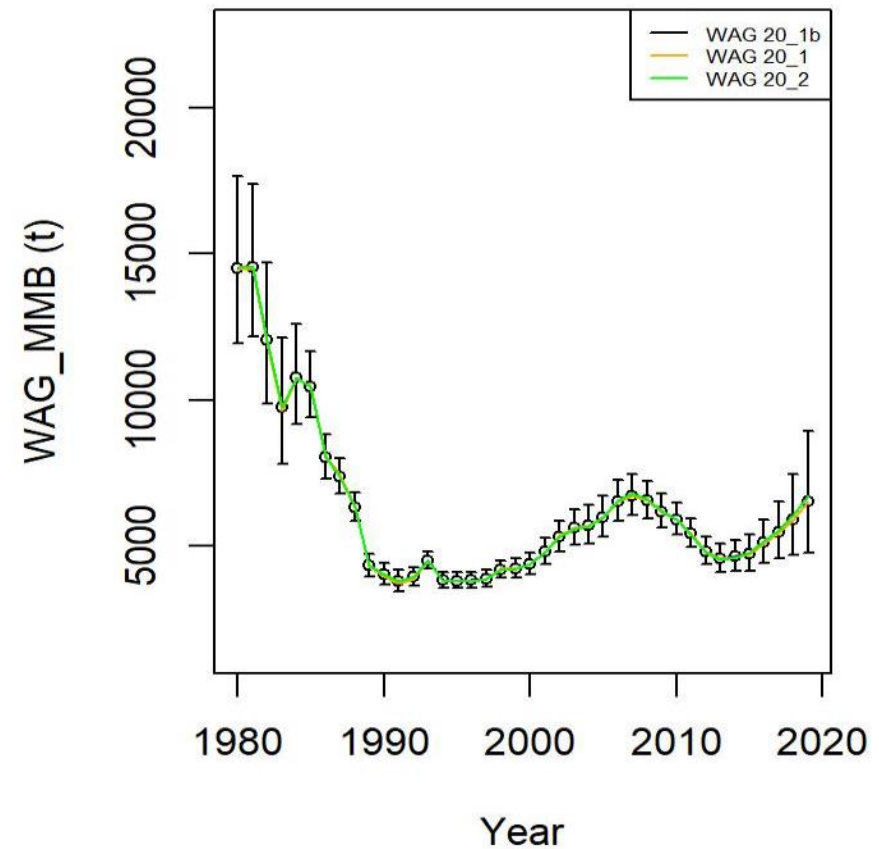
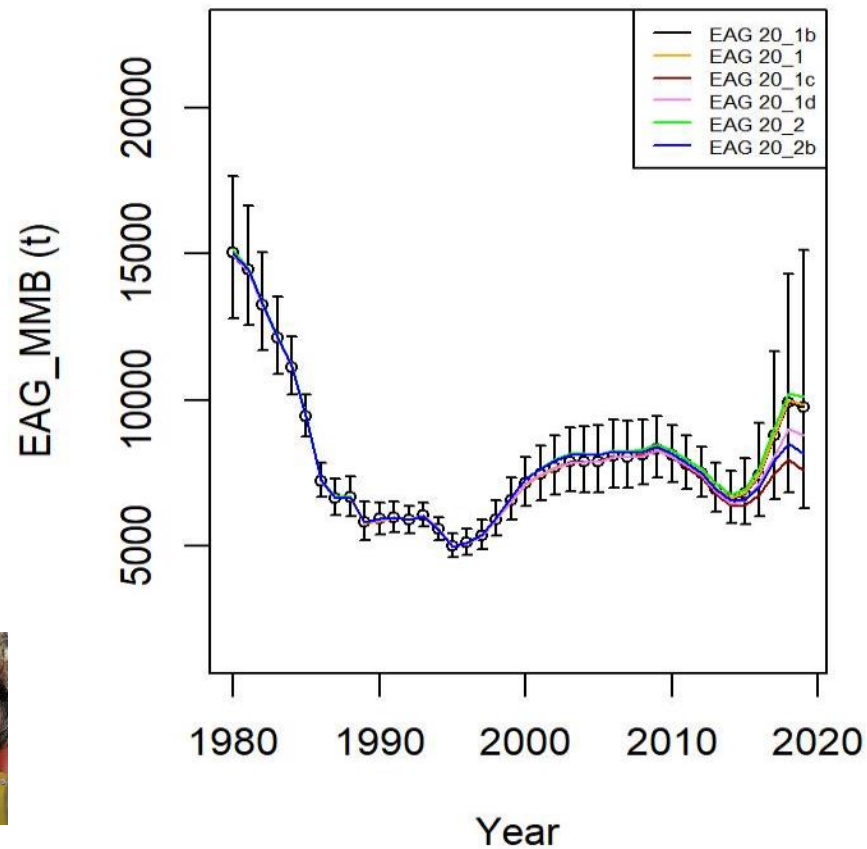

FIG. 26. TRENDS IN GOLDEN KING CRAB MATURE MALE BIOMASS FOR MODELS 20_1, 20_1B, 20_1C, 20_1D, 20_2, AND 20_2B FITS TO **EAG** (LEFT) AND MODELS 20_1, 20_1B, AND 20_2 FITS TO **WAG** (RIGHT) DATA, 1960/61–2019/20. MODEL 20_1B ESTIMATE HAS TWO STANDARD ERROR CONFIDENCE LIMITS.



ALEUTIAN IS. GOLDEN KING CRAB

■ Issues

- Changes in recruitment parameterization in the models after the base model was problematic for moving forward with those models for specifications
- Year:Area models need better documentation and review (20.2 and 20.2b), the variance calculation specifically
- Cooperative survey CPUE indices (only for EAG) need review of 2019 data, also sensitivity of this new data set to the model output needed (20.1c and 20.1d)

■ Recommendations:

- Model 20.1b
 - uses the 70% recruitment calcs previously used
 - Improvement to the base model with the use of the negative binomial
- Explore the sensitivity of the results to levels of R_{σ} in the future
- Improved graphical depictions, and additional figures needed for cooperative survey data
- GMACS version in the near future



AIGKC SPECIFICATIONS USING MODEL 20.1B USING 70% RECRUITMENT

Status and catch specifications (1000 t) for Aleutian Islands golden king crab. Shaded values are new estimates or projections based on the current assessment. Other table entries are based on historical assessments and are not updated except for total and retained catch.

Year	MSST	Biomass (MMB)	TAC	Retained Catch	Total Catch	OFL	ABC
2016/17	N/A	N/A	2.515	2.593	2.947	5.69	4.26
2017/18	6.044	14.205	2.515	2.585	2.942	6.048	4.536
2018/19	5.880	17.848	2.883	2.965	3.355	5.514	4.136
2019/20	5.909	16.323	3.257	3.275	3.693	5.249	3.937
2020/21		14.774				4.798	3.599



WESTERN ALEUTIAN IS. RED KING CRAB

- Tier 5 stock, last assessment May 2017 (3-yr cycle)
- No changes in assessment methodologies (status quo)
- Updated catch history
- Overfishing did not occur during 2017/18, 2018/19, and 2019/20 seasons
- 2016 Petrel Bank survey indicates low population abundance



WAIRKC RECOMMENDED SPECIFICATIONS

Management Performance Table (values in t)

Fishing Year	MSST	Biomass (MMB)	TAC^a	Retained Catch	Total Catch	OFL	ABC
2015/16	N/A	N/A	Closed	0	1.3	56	34
2016/17	N/A	N/A	Closed	0	<1	56	34
2017/18	N/A	N/A	Closed	0	<1	56	14
2018/19	N/A	N/A	Closed	0	<1	56	14
2019/20	N/A	N/A	Closed	0	<1	56	14
2020/21	N/A	N/A				56	14
2021/22	N/A	N/A				56	14
2022/23	N/A	N/A				56	14

- a. Pre-season harvest levels are established as total allowable catch for the rationalized fishery west of 179° W longitude and as a guideline harvest level for the non-rationalized fishery east of 179° W longitude.



PRIBILOF IS. GOLDEN KING CRAB

- Tier 5; last assessment May 2017 (3-yr cycle)
- Managed by calendar year: Jan 1-Dec 31
- Fishery data
 - 100% observer coverage
 - 100% dockside sampled
- Commissioner's Permit fishery
- Increased interest
 - Decline in other BSAI crab fisheries
 - Requests for increased GHs - currently 130,000 lb
- Tier 4 random effects (RE) model development
 - Slope survey results



PIGKC : SLOPE SURVEY

PRIBILOF DISTRICT MANAGEMENT AREA INTERSECTS SUBAREAS 1, 4, 5

**Pribilof
District**

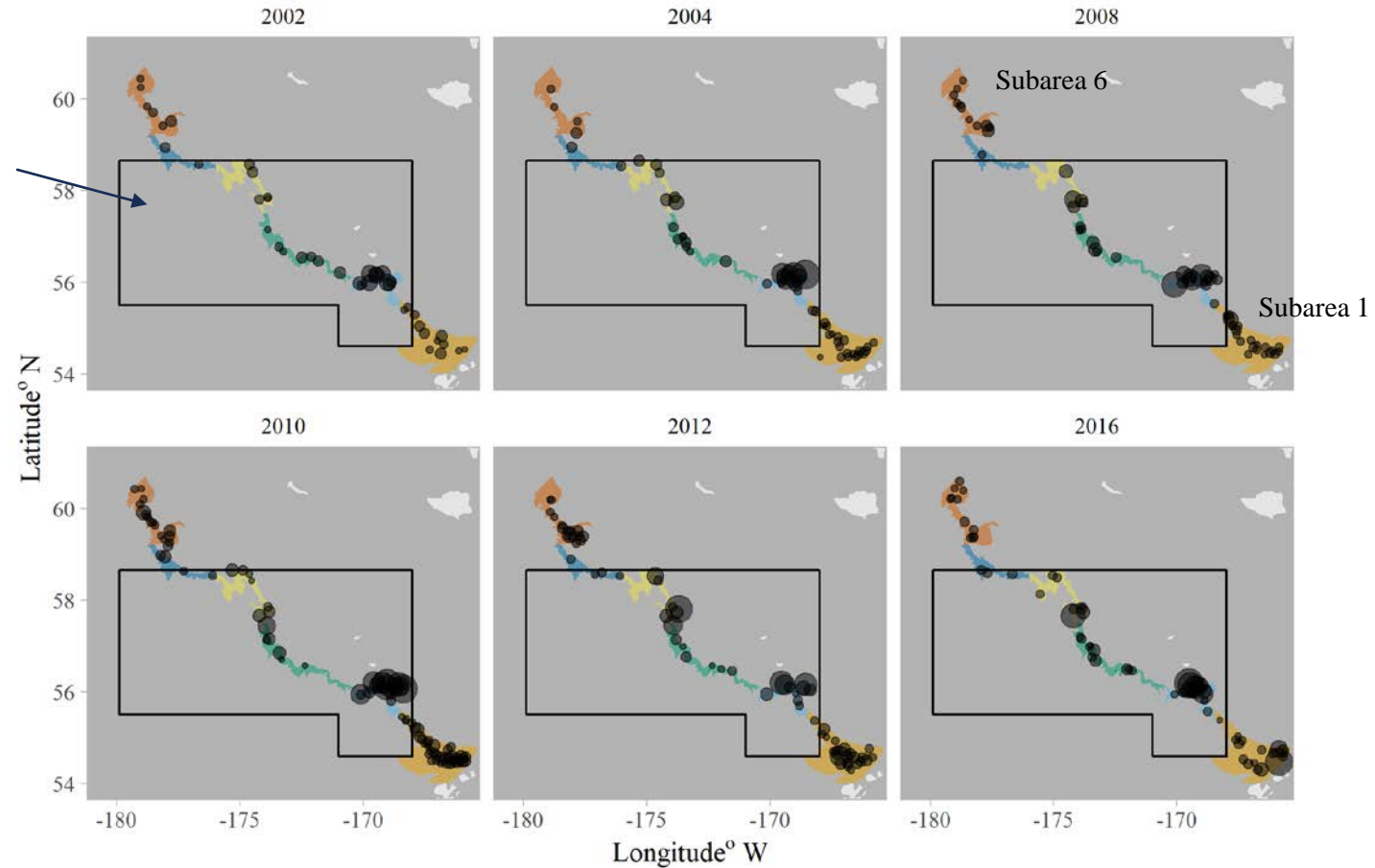

PIGKC : RE MODEL

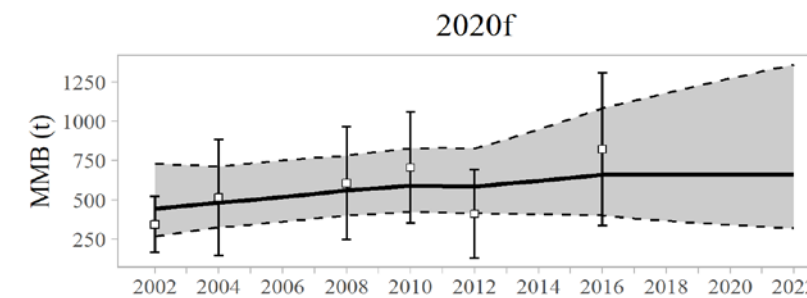
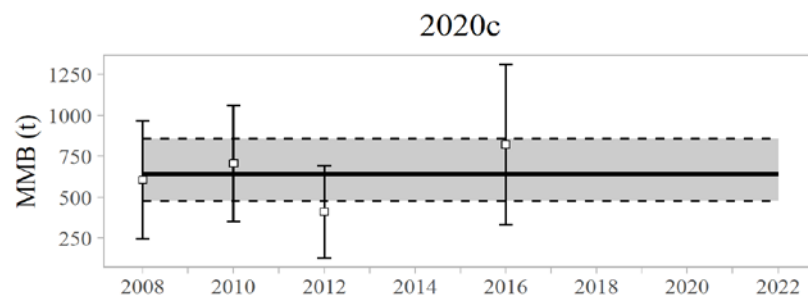
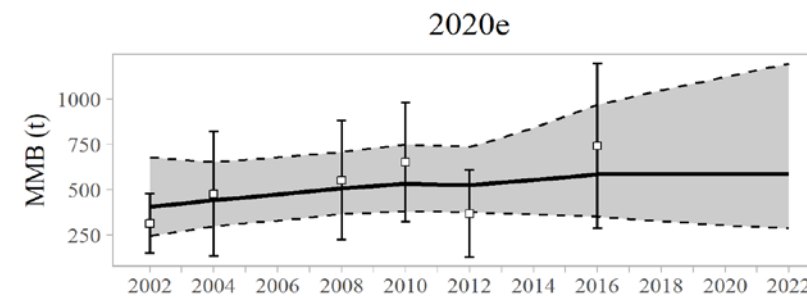
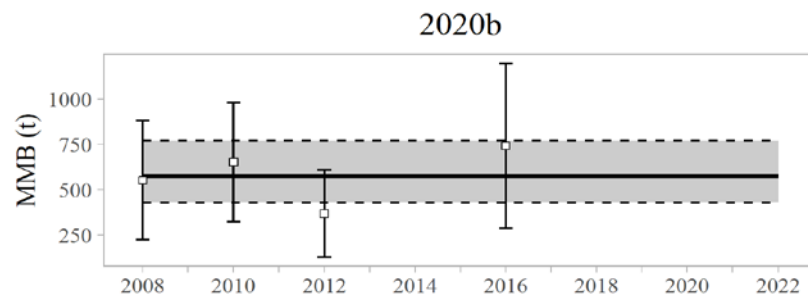
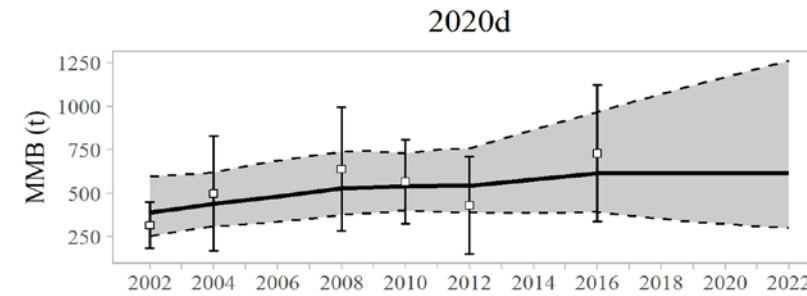
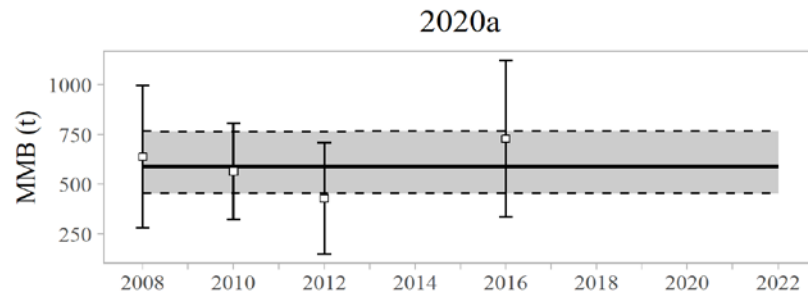

PIGKC: RECOMMENDATIONS

- Tier 5 specifications
- Bring tier 4 model for work during the Jan 2021 modeling workshop, with a presentation at May 2021 meeting for possible adoption
- Tier 4 improvements:
 - Explore 2004 size comp data availability
 - Improve CV for 2002 and 2004 MMB estimates
 - Explore simple GMACS model



PIGKC:TIER 5 SPECIFICATIONS

Management Performance Table (values in t)

Calendar Year	MSST	Biomass (MMB)	GHL ^a	Retained Catch	Total Catch ^b	OFL	ABC
2016	N/A	N/A	59	0	0.24	91	68
2017	N/A	N/A	59	Conf. ^c	Conf. ^c	93	70
2018	N/A	N/A	59	Conf. ^c	Conf. ^c	93	70
2019	N/A	N/A	59	Conf. ^c	Conf. ^c	93	70
2020	N/A	N/A	59			93	70
2021	N/A	N/A				93	70
2022	N/A	N/A				93	70
2023	N/A	N/A				93	70



SUMMER TRAWL SURVEY PLANNING

- Lyle Britt of GAP presented possible scenarios for summer 2020 EBS trawl surveys.
 - June 20 start: Data available for BBRKC and Tanner, snow crab data and assessment delayed.
 - July 11 start: Data available for BBRKC and Tanner, snow crab data and assessment delayed.
 - Aug 1 start: No data available for any crab stock for Sept. All assessments will be delayed.
 - **No survey:** No data available for any crab stock. No delay in assessments.
 - CPT recommended that stock assessment authors use last year's accepted model, incorporating updated fishery data (complete for 2019/2020 fishing year).
 - CPT also recommends bringing forward alternative preferred models from the May meeting for consideration with updated fishery data



VAST MODEL

- GAP/SAP has developed a standard approach for producing VAST estimates for use in assessment models
- Jon Richar provided VAST estimates to crab assessment authors in April, sufficiently early for assessment authors to include exploratory model runs for the May CPT meeting
- If a model with VAST is accepted, GAP/SAP believes that it can produce VAST estimates in the fall in time for final model runs.
- Model diagnostics suggest VAST estimates not ready for assessment
- CPT would like to revisit VAST estimates at Jan meeting



BSFRF SURVEY SELECTIVITY

- Dr. Buck Stockhausen gave a summary of method he and others have used to incorporate the BSFRF survey selectivity data into crab assessments
- Goals
 - Review and update of methods currently examined and used
 - Eventually adopt similar methods to incorporate this data set in Tanner, snow, and BBRKC models
- Recommendations:
 - Address the use of samples sizes in the model (number of crab per size bin)
 - Explore GAMM's to treat "year" as a random effect on catchability
 - Address large differences in annual estimates of empirical catchability by incorporating differences in catchability across years.



BRISTOL BAY RED KING CRAB (BBRKC) MODEL RUN OPTIONS

- Model uses GMACS framework (implemented in Sept. 2019)
- 8 model scenarios considered
- Addressed parameterization in:
 - Natural mortality
 - Survey selectivity differences by sexes
 - Catchability differences by sexes
 - Using VAST estimates of survey data
- CPT recommends models that include:
 - constant M males 1980-1984, $M = 0.18$ for males during other years
 - estimated constant multiplier for females
 - Survey selectivity separate by sexes, with single catchability (Q)



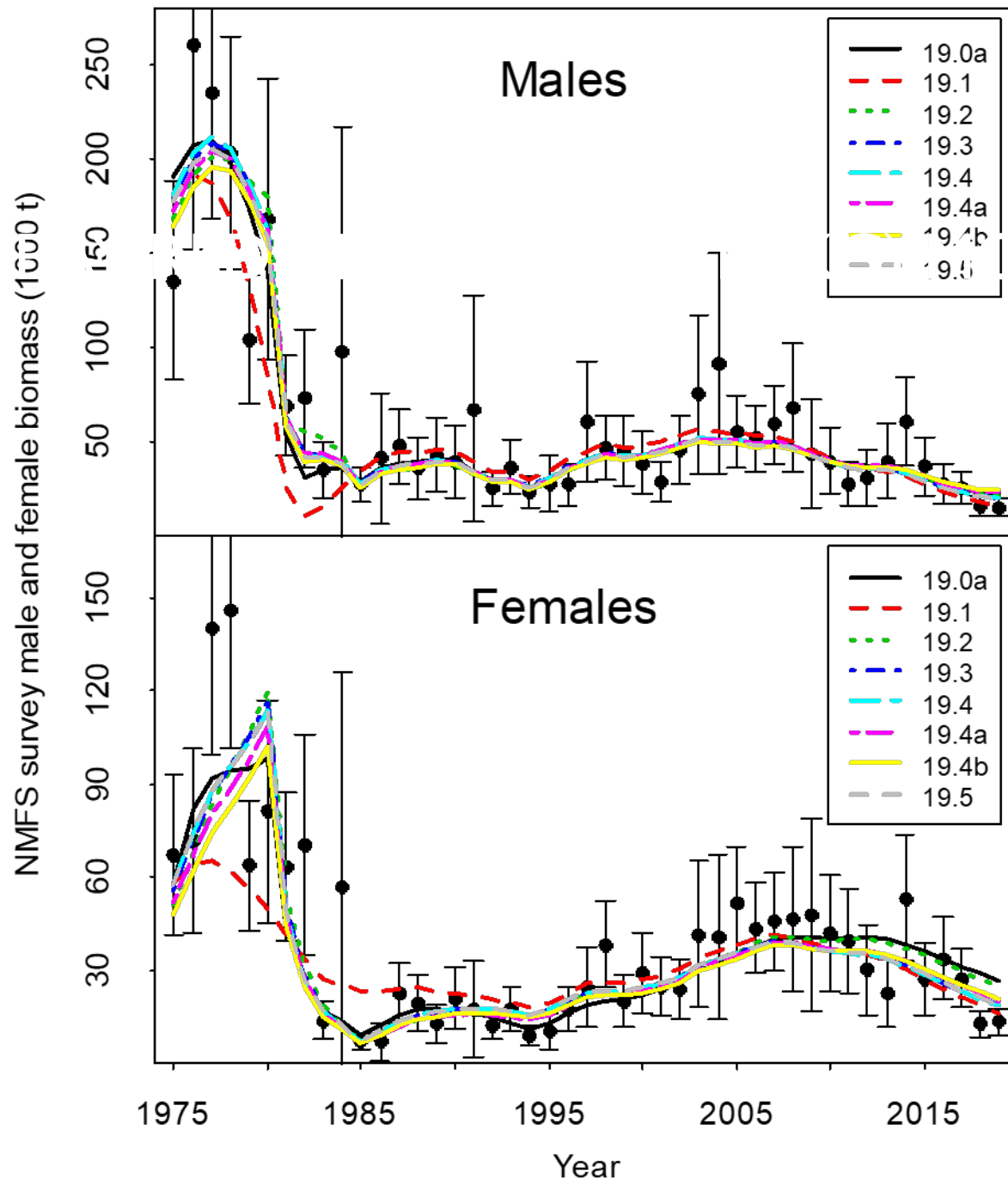

Comparisons of area-swept estimates of total NMFS survey biomass and model prediction for model estimates in 2019 under eight models. The error bars are plus and minus 2 standard deviations.



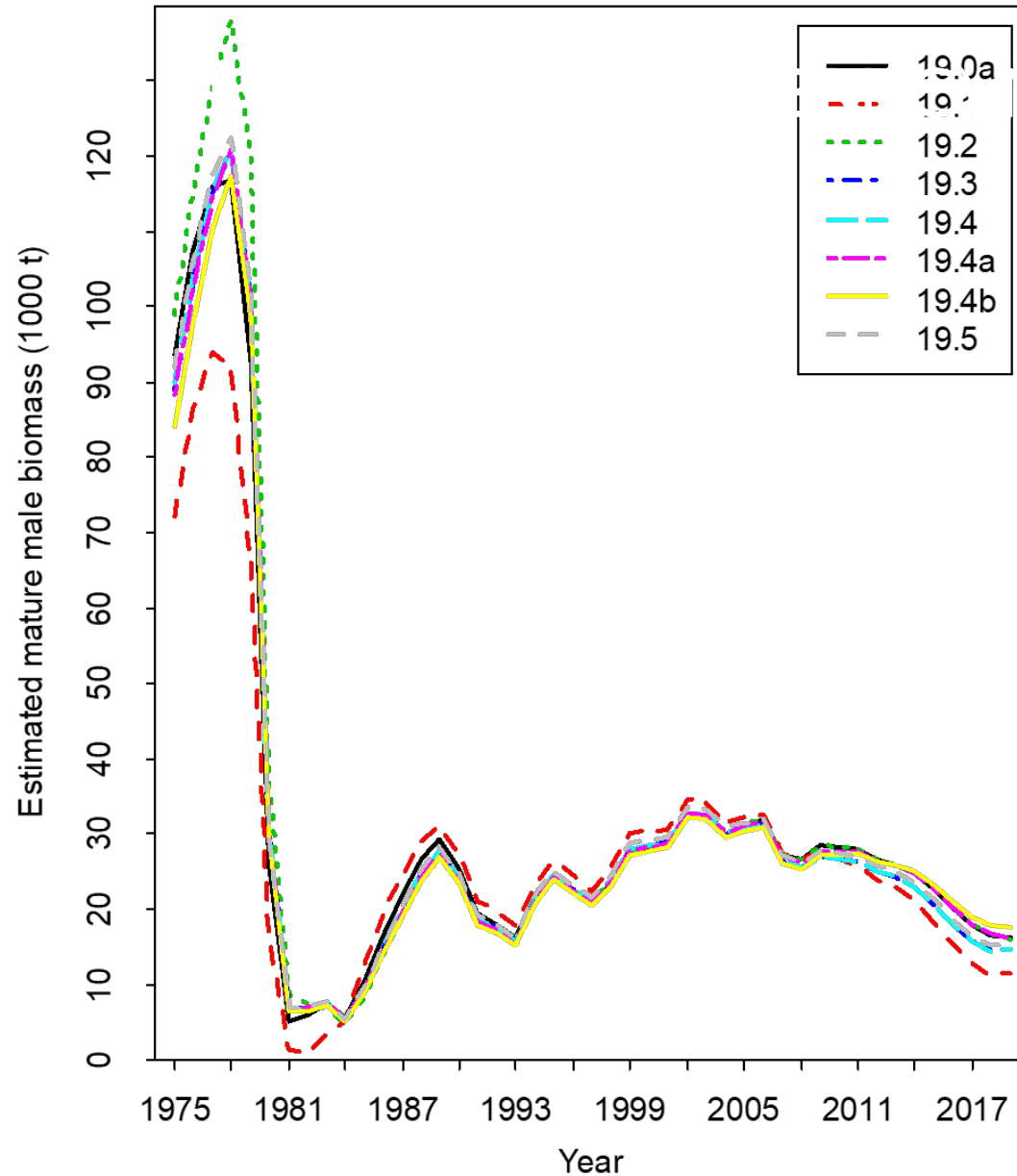

Comparisons of mature male biomass on Feb. 15 under eight models.

Estimated trawl survey catchabilities:

Model	Q
19.0a	0.930
19.1	0.972
19.2	0.915
19.3	0.950
19.4	0.951
19.4a	0.936
19.4b	0.920
19.5	0.92/0.94



BOARD OF FISHERIES UPDATE DISCUSSION OF ACTION ON TANNER CRAB

- Ben Daly (ADF&G Kodiak) presented MSE that evaluated alternative State harvest strategies for Tanner crab
- Positive collaboration
 - ADF&G developed new harvest strategy options
 - Industry stakeholders provided feedback throughout
 - High value fishery, variable TAC, closures, complex harvest strategy
 - NOAA and UW conducted the analysis
 - 15 harvest strategies evaluated
 - Narrowed down to 1 strategy with 3 sub-options for BOF consideration
 - Alignment across collaborators, with some differences in final preference
- This was a strong collaborative effort



PROPOSAL 261

RECOMMENDED HARVEST STRATEGY FOR BERING SEA TANNER CRAB

Benjamin Daly¹, Madison Heller-Shipley², Mark Stichert¹, William Stockhausen³, André Punt², Scott Goodman⁴

Alaska Board of Fisheries Meeting

Anchorage, AK

March 8-11, 2020

¹ Alaska Department of Fish and Game, ² University of Washington, ³ National Oceanic and Atmospheric Administration, ⁴ Natural Resources Consultants Inc.



³ The scientific results and conclusions, as well as any views or opinions expressed herein, are those of the author(s) and do not necessarily reflect those of NOAA or the Department of Commerce.

TANNER CRAB PROPOSED MODEL RUNS FOR SEPT

- Buck Stockhausen presented the draft Tanner crab assessment
- Analyses included:
 - Size-weight relationships
 - Empirical availability from side by side (SBS) studies
 - Empirical catchability from SBS studies
 - VAST estimates of survey biomass
- Nine model scenarios were presented



SNOW CRAB PROPOSED MODEL RUNS FOR SEPT

- Major focus was implementing this model in GMACS
- CPT recommendations include the following:
 - Identify the cause of the “pigtails” in the retained catch size compositions.
 - Implement reference point calculations in GMACS for status determination and OFL calculation.
- Bring forward the following alternative model scenarios for the September CPT Meeting:
 - Status quo model with updated data.
 - “Free q” GMACS model with updated data.
 - “Prior q” GMACS model with updated data.



SNOW CRAB PROPOSED MODEL RUNS FOR SEPT

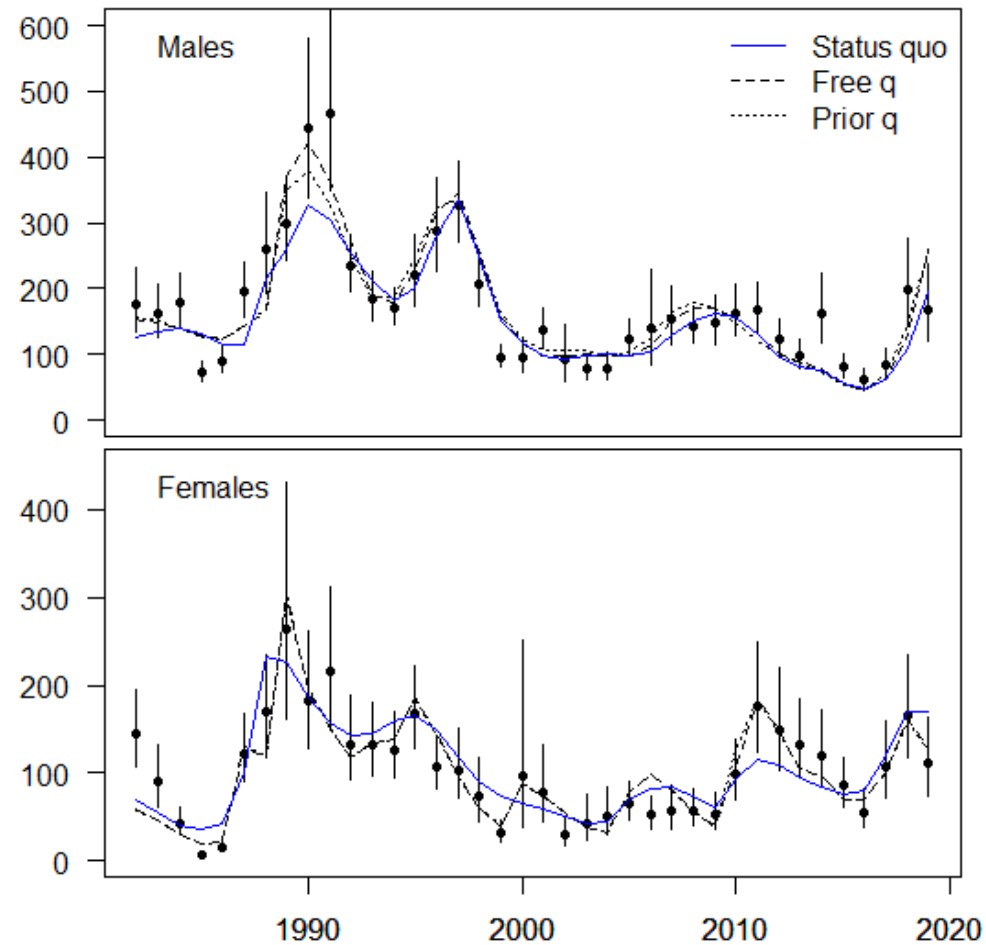

ST MATTHEW IS. BLUE KING CRAB PROPOSED MODEL RUNS FOR SEPT

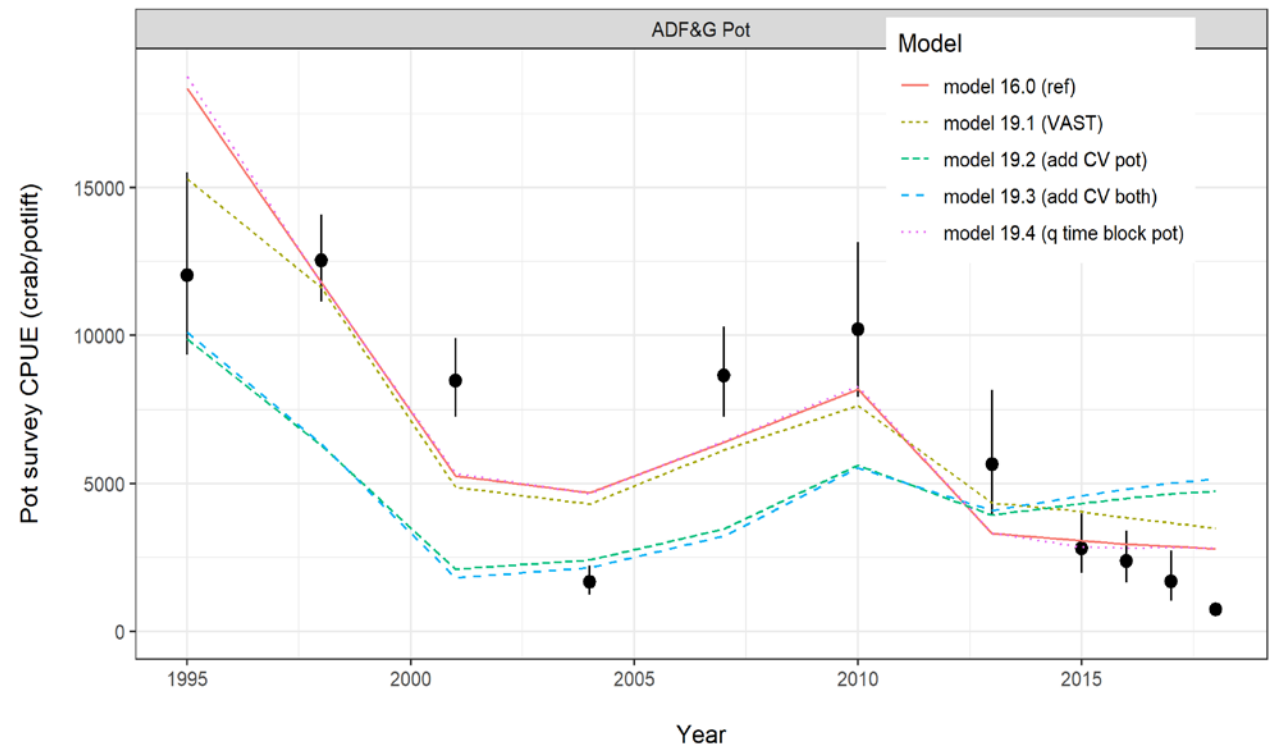
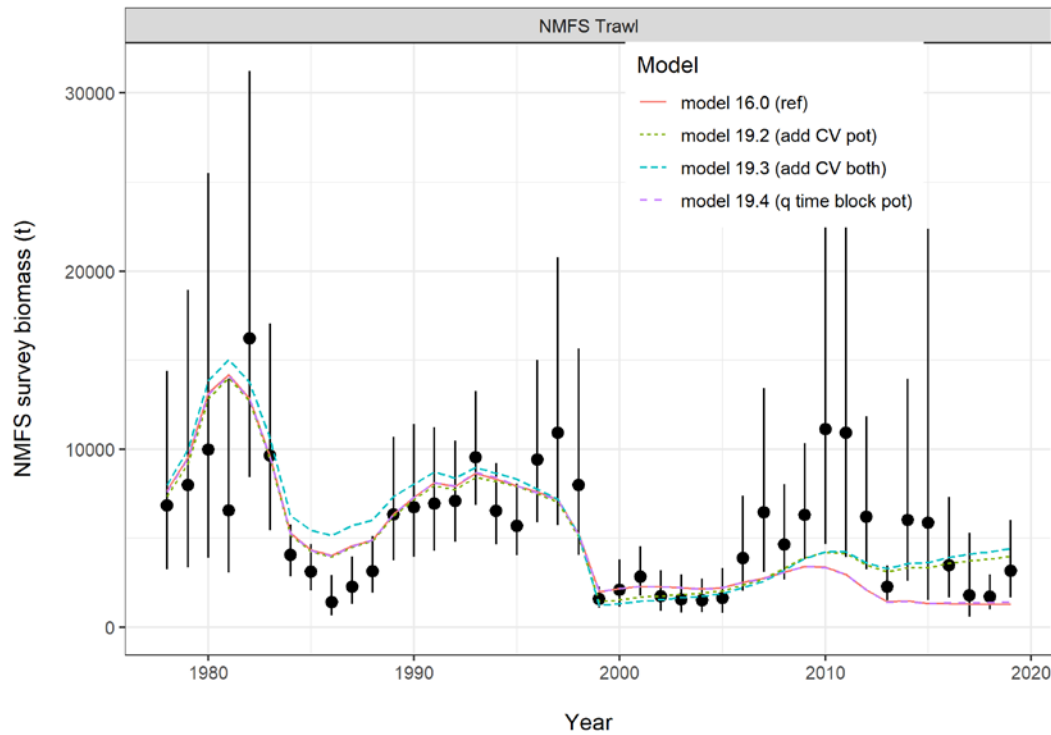

ST MATTHEW IS. BLUE KING CRAB PROPOSED MODEL RUNS FOR SEPT

- CPT Recommendations:
- Provide results for the following four models for September 2020:
 - Model 16.0.
 - Model 19.1 (VAST).
 - A model with a random walk in pot survey catchability.
 - Model 16.0 without ADF&G pot survey data.
- Other recommendations
 - Conduct a retrospective analysis for the base model.
 - Initiate a spatial analysis of NMFS trawl and ADF&G pot survey



BBRKC ECOSYSTEM PROCESSES

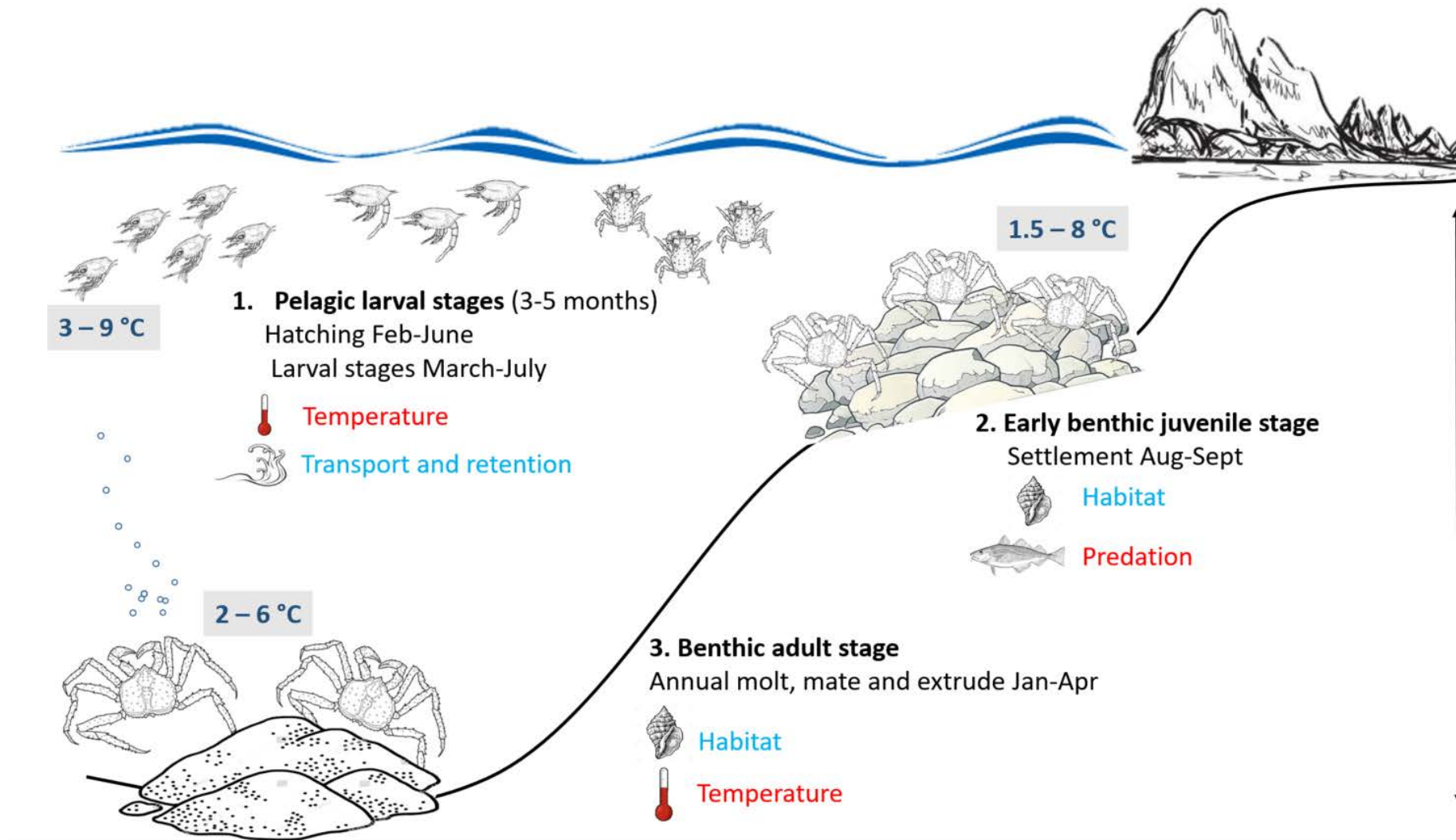

CLIMATE CHANGE AND LT/TK FOR NSRKC

- SSC has suggested that the Climate Change Taskforce (CCTF) and the LKTK TF use Norton Sound red king crab fishery as a case study
- CPT met with the co-chairs of the Local Knowledge, Traditional Knowledge, and Subsistence Taskforce (LK/TK TF) and Climate Change Taskforce
 - LK/TK TF Agreed that NSRKC would be a good case study (next meeting Fall 2020)
 - Case study put on hold due to COVID-19 travel restrictions
 - Emphasized the need to develop a community-driven plan.
 - CCTF included NSRKC on the list of potential test cases but did not make a decision.
- CPT Recommends:
 - Requesting knowledge from local stakeholders to be presented at Sept / Jan CPT meetings
 - Formation of a committee composed of local stakeholders, community members, and ADF&G representatives
 - Informally request information to start the conversation
 - Report back to CPT
 - SSC recommends waiting to ensure respect for these communities and potential harm to relationships during an informal process



OTHER AGENDA ITEMS

- GMACS update
 - SMBKC, BBRKC, PIRKC using GMACS
 - Snow crab – model runs for Sept.
 - NSRKC, AIGKC – drafts expected in 2021
- Crab PSC (initial review in Oct)
 - CPT provided feedback on potential analyses
- Climate change and LT/TK for NSRKC
 - Response to SSC request
 - Collaborate with LT/TK task force and climate change task force
- New business
 - Planning for Sept and Jan meetings



QUESTIONS?

Thanks to all CPT members and participants for a successful CPT meetings.

Presentation prepared with input from:

- *Assessment authors and CPT members*

KATIE PALOF

KATIE.PALOF@ALASKA.GOV

&

MARTIN DORN

MARTIN.DORN@NOAA.GOV

NEW BUSINESS: SEPTEMBER 2020 CPT MEETING

- The meeting will be held in Seattle from September 14-18.
- Proposed agenda items include:
 - Final 2020 SAFE chapters for BBRKC, SMBKC, Tanner and snow crab
 - Update bycatch estimates for WAIRKC and PIGKC to determine final overfishing status
 - Proposed model runs for January CPT meeting for NSRKC including GMACS
 - LK/TK draft input for NSRKC
 - Research reports on snow crab:
 - Spatial model
 - Individual-based model with incorporation of ROMS inputs
 - Tanner crab MSE
 - Final report for NPRB project on Pribilof Island blue king crab



NEW BUSINESS: JANUARY 2021 CPT MEETING

- The meeting will be held in Anchorage during the week of January 11-15.
- Final 2021 NSRKC assessment, which will include consideration of LK/TK input.
- Proposed model runs for AIGKC will be reviewed, including GMACS application.
- Review stock assessment terms of reference.
- Modeling workshop will be held after CPT meeting.
- Likely topics include GMACS and VAST diagnostics, but others may be added.

