

---

# C3 IFQ SABLEFISH RELEASE ALLOWANCE

FEBRUARY 2021



JIM ARMSTRONG, COUNCIL STAFF  
JOE KRIEGER, PHD, NMFS-AKRO

# ACTION

Amend the Groundfish FMPs and Federal Regulations to allow participants in the IFQ sablefish fishery to release sablefish caught with fixed gear

Council Initial Review

Action memo

Draft analysis

Public comment



# OVERVIEW

- Analysis builds on information provided in a series of discussion papers, with added development of observer issues, population impacts, fishery impacts
- **Workgroup staff available for questions** – Jen Cahalan (PSMFC), Phil Ganz (NMFS), Dan Goethel (NMFS), Chris Lunsford (NMFS), Jane Sullivan (NMFS)



# BACKGROUND

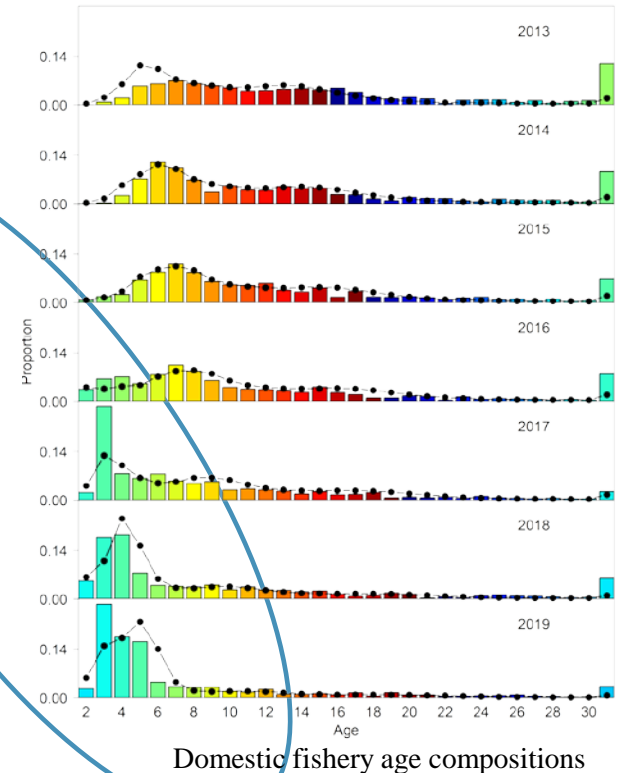
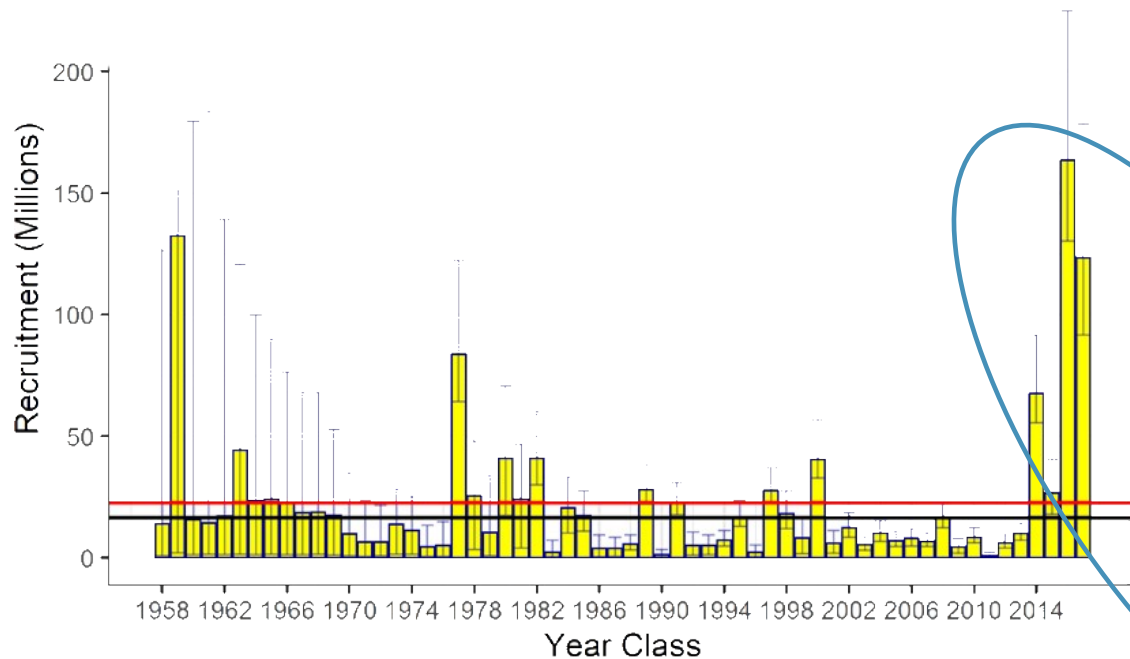

- Big year classes
- Stakeholder testimony since 2018
- Series of Discussion Papers



# PURPOSE AND NEED

Large year classes of sablefish result in significant catches of small sablefish in the IFQ fixed gear fisheries. Small sablefish have low commercial value and current regulations require IFQ holders to retain all sablefish. Available data suggest that survival rates for carefully released sablefish are high. Operational flexibility to carefully release sablefish may increase the value of the commercial harvest and allow small fish to contribute to the overall biomass.



# ALTERNATIVES

- Alternative 1 - No Action
- Alternative 2 - Voluntary Release by IFQ Fishery
  - Element 1: DMRs:
    - 5%, 12%, 16%, 20%
    - Sub-option: Different DMRs for pots, HAL
  - Element 2: Catch Accounting
    - Option 1: Observer/EM
    - Option 2: Longline survey catches of sablefish
  - Element 3: Discard Mortality Accounting - Discard mortality accounted for in the stock assessment.
  - Element 4: Monitoring and Enforcement - Provisions that could improve discard estimates



# ELEMENT 1: DMR

- Apply a DMR to discarded sablefish of:
  - 5% (GOA Halibut Pot DMR)
  - 12% (Stachura et al.)
  - 16% (State of Alaska)
  - 20% (PFMC)
- DMRs result in:
  - ABC reduction\*
  - Redirection of fishing effort
  - Increased fishing effort





# ELEMENT 1: DMR

- Key DMR takeaways.
  - 1-3 lbs. range to delineate “small” sablefish
  - More small fish in catch greater the difference between DMRs
  - Only ~ 3.3 % (474,000 lbs.) difference in 2020





# ELEMENT 1: DMR

- *Sub-option: Select different DMRs for pot gear and hook and line gear*
- HAL – same as previously addressed
- Pot Gear
  - 7% (halibut in pots 2018)
  - 4% (halibut in pots 2019)
  - 0% (halibut in pots 2020)
- Key gear-specific DMR takeaways.
  - Reductions in landed sablefish ~ 4x higher in pot vs HAL
  - More harvest of sablefish by pots in 2020
  - Substantial difference in the amount of discard-able fish between pot and HAL DMRs



# DMR CONSIDERATIONS

- Underestimating the DMR
  - Post-release depredation
  - 30% DMR used in British Columbia



# ELEMENT 2: CATCH ACCOUNTING

- Element 2: Catch Accounting
  - Option 1: Sablefish discards will be estimated using observer and EM data with a DMR applied annually as part of the specifications process.
  - Option 2: Sablefish discards will be estimated pre-season based on AFSC longline survey encounter rates of sub-three-pound sablefish with the DMR applied annually as part of the specifications process.



# ELEMENT 2: CATCH ACCOUNTING

- Option 1: Sablefish discards will be estimated using observer and EM data with a DMR applied annually as part of the specifications process.

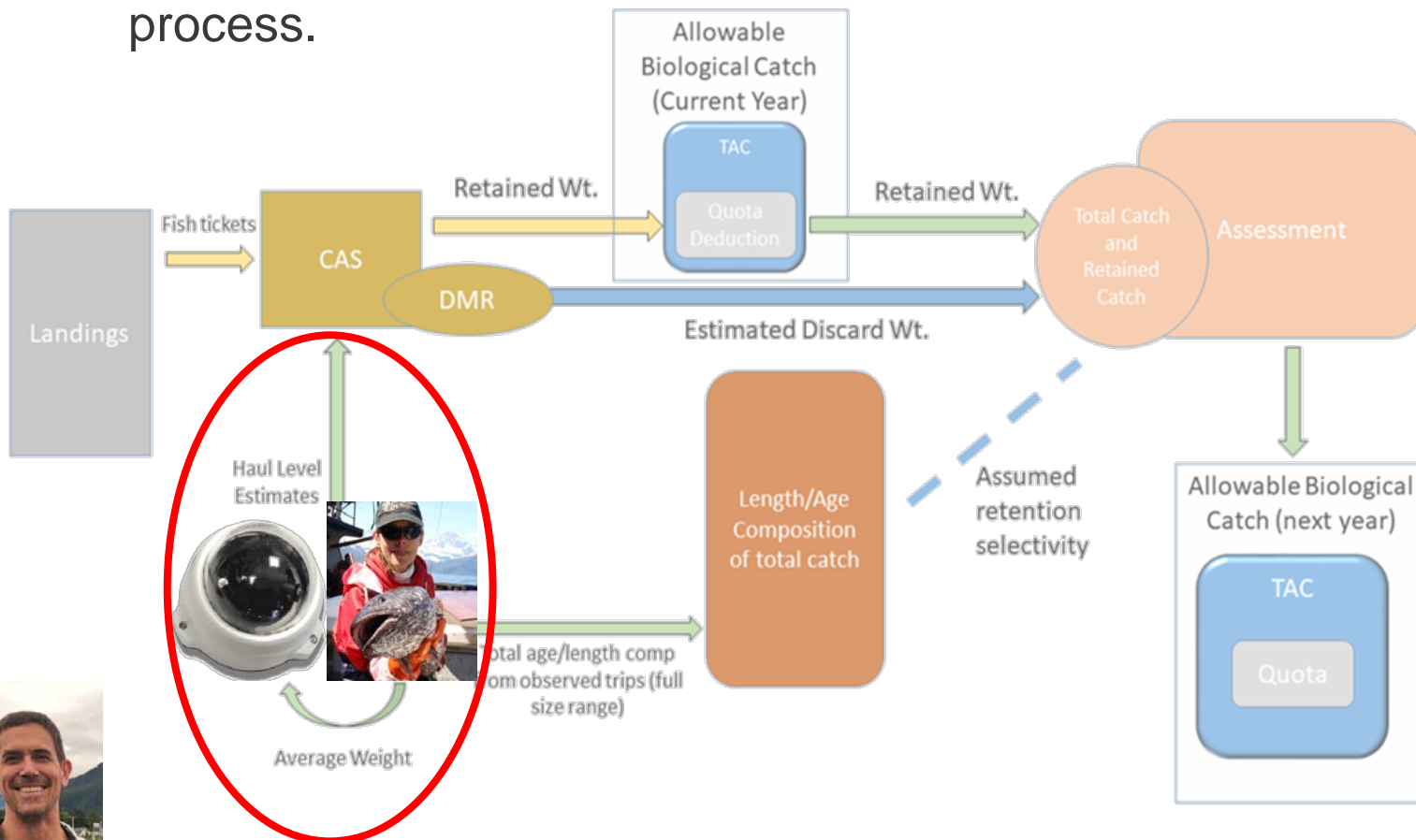

# ELEMENT 2: CATCH ACCOUNTING

- Option 1: Sablefish discards will be estimated using observer and EM data with a DMR applied annually as part of the specifications process.
- Implementation needs:
  - Differentiate size composition of released and retained
  - Prevent observer effect
  - Ensure observer safety and work within vessel size constraints
  - Make necessary changes to database



# ELEMENT 2: CATCH ACCOUNTING

## ■ Potential solution

- Discards = Total weight (Obs) – Landed weight (FT)
- Match landings with observed trips
- Verify consistency in landed and obs-based retained
- Update PRRs
- Added information from EM

$$\hat{D} = N \left[ \frac{\sum_m \hat{w}}{n_m} \right] - \sum_{all} R$$

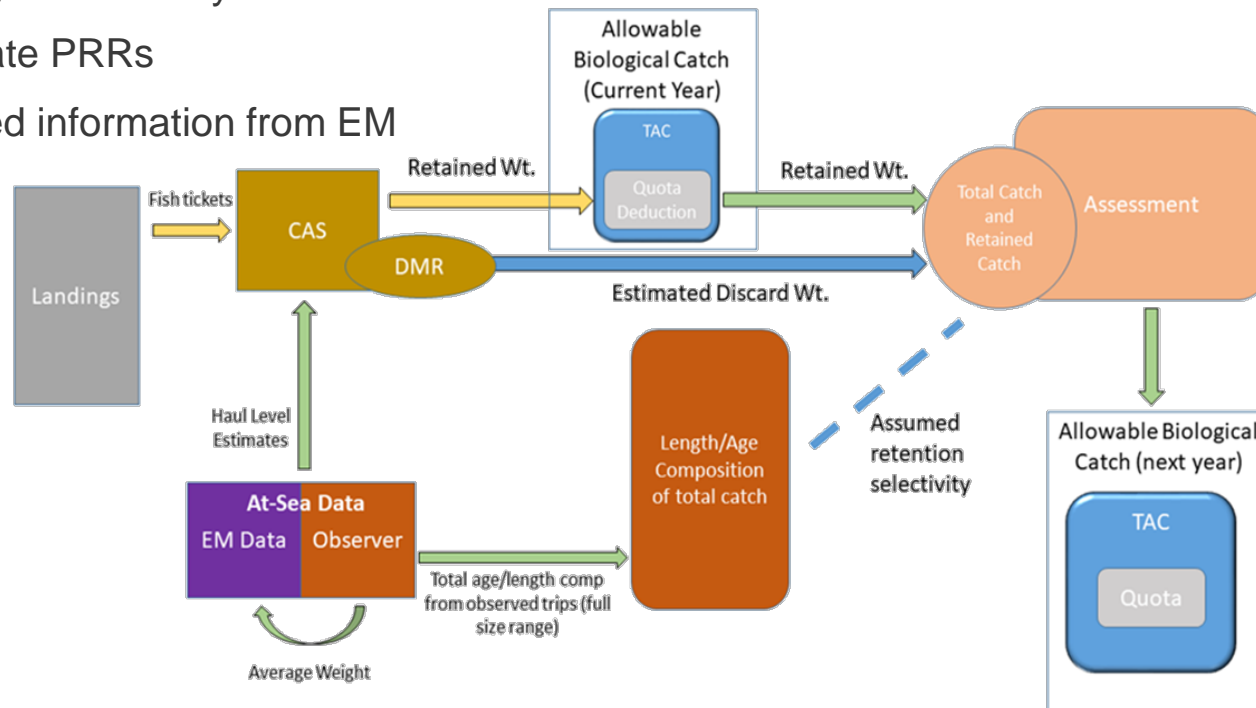

# ELEMENT 2: CATCH ACCOUNTING

- Option 2: Sablefish discards will be estimated pre-season based on AFSC longline survey encounter rates of sub-three-pound sablefish with the DMR applied annually as part of the specifications process.



Magnitude of wastage estimates has been based on the rate of **sublegal to legal** catch rates in the setline survey.

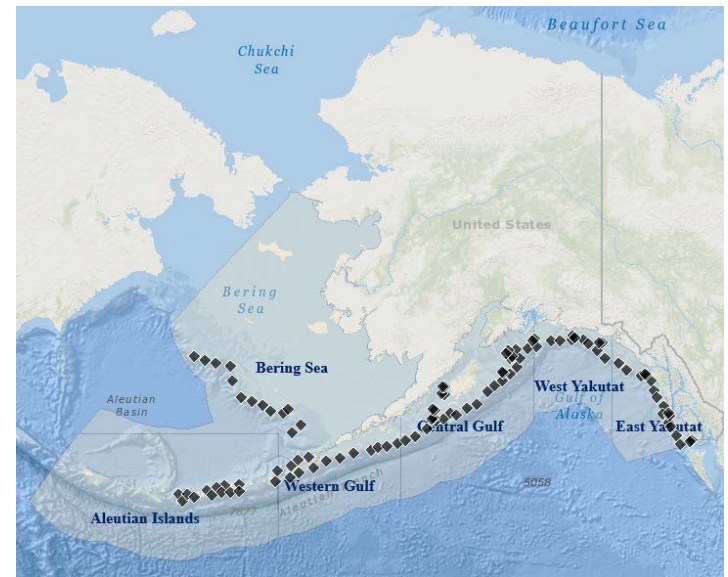



# ELEMENT 2: CATCH ACCOUNTING

- Option 2: Sablefish discards will be estimated pre-season based on AFSC longline survey encounter rates of sub-three-pound sablefish with the DMR applied annually as part of the specifications process.

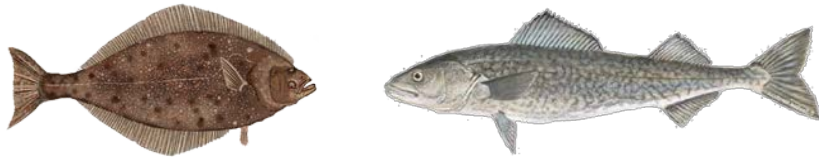

Magnitude of wastage estimates has been based on the rate of **sublegal to legal** catch rates in the setline survey.

**Not viable approach without minimum size limit**

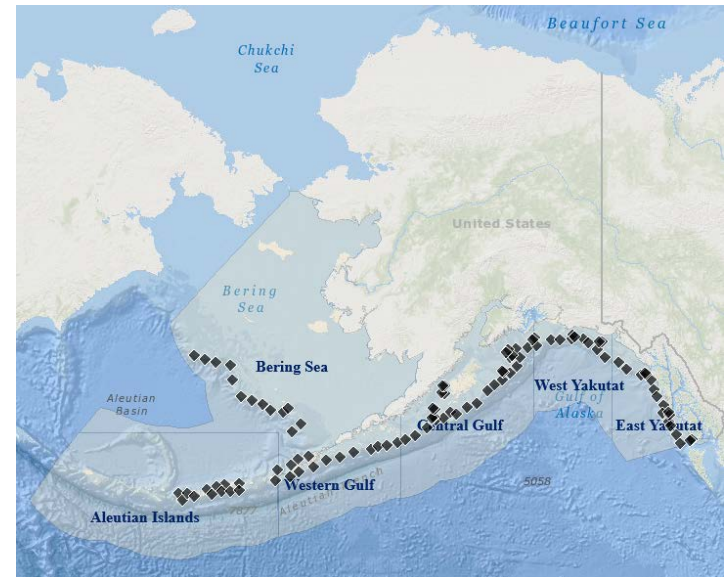
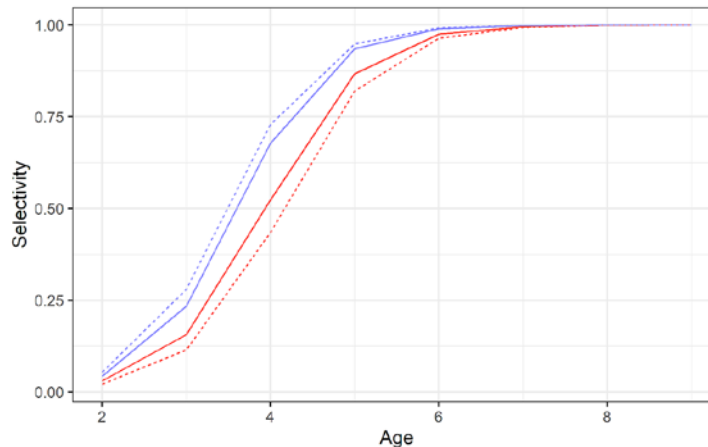

Sex  
— Female  
--- Male

Source  
— Fixed gear fishery  
— Longline survey



## ELEMENT 3: DISCARD MORTALITY ACCOUNTING

**“Sablefish discard mortality associated with the IFQ fishery will be accounted for in the stock assessment. The analysis should describe the potential implications of voluntary discards on the sablefish stock assessment and specifications process.”**



<https://www.pacificseafood.com/species/sablefish/>

# ELEMENT 3: DISCARD MORTALITY ACCOUNTING

*Impact of fishery discard on catch accounting and stock assessment*

**What sizes of fish will be retained vs. discarded?**

**How many discarded fish will die?**

Alternative retention selectivity curves

**Retained catch**

**Discarded catch**

DMR = ✗

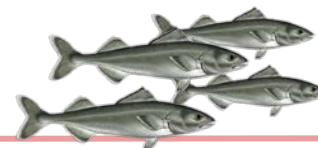
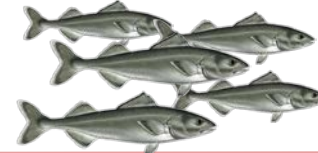
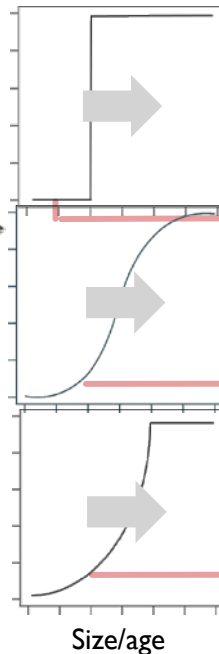
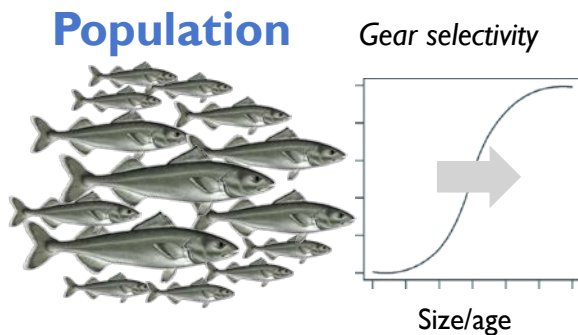

# ELEMENT 3: DISCARD MORTALITY ACCOUNTING

**Increasing  
stock  
assessment  
uncertainty**



Scenarios	Data used in stock assessment	Ability to estimate:			Example
		<i>Gear selectivity</i>	<i>Retention selectivity</i>	<i>Discard mortality rate (DMR)</i>	
<b>Mandatory retention with at-sea observers</b>	Sample total catch	Yes	<i>Not needed</i>	<i>Not needed</i>	Status quo
<b>Voluntary discarding with at-sea observers paired with shoreside sampling</b>	Sample retained catch <i>and</i> the total catch	Yes	Yes	No	BSAI king, snow, and tanner crabs
<b>Minimum size limit with at-sea observers</b>	Sample total catch	Yes	Assume full retention at minimum size limit	No	--
<b>Voluntary discards with at-sea observers only</b>	Sample total catch	Yes (but may increase uncertainty)	No	No	--
<b>Voluntary discards with shoreside sampling only</b>	Sample retained catch	No	No	No	Chatham Strait sablefish



# ELEMENT 3: DISCARD MORTALITY ACCOUNTING

Retention selectivity as a function of dressed weight

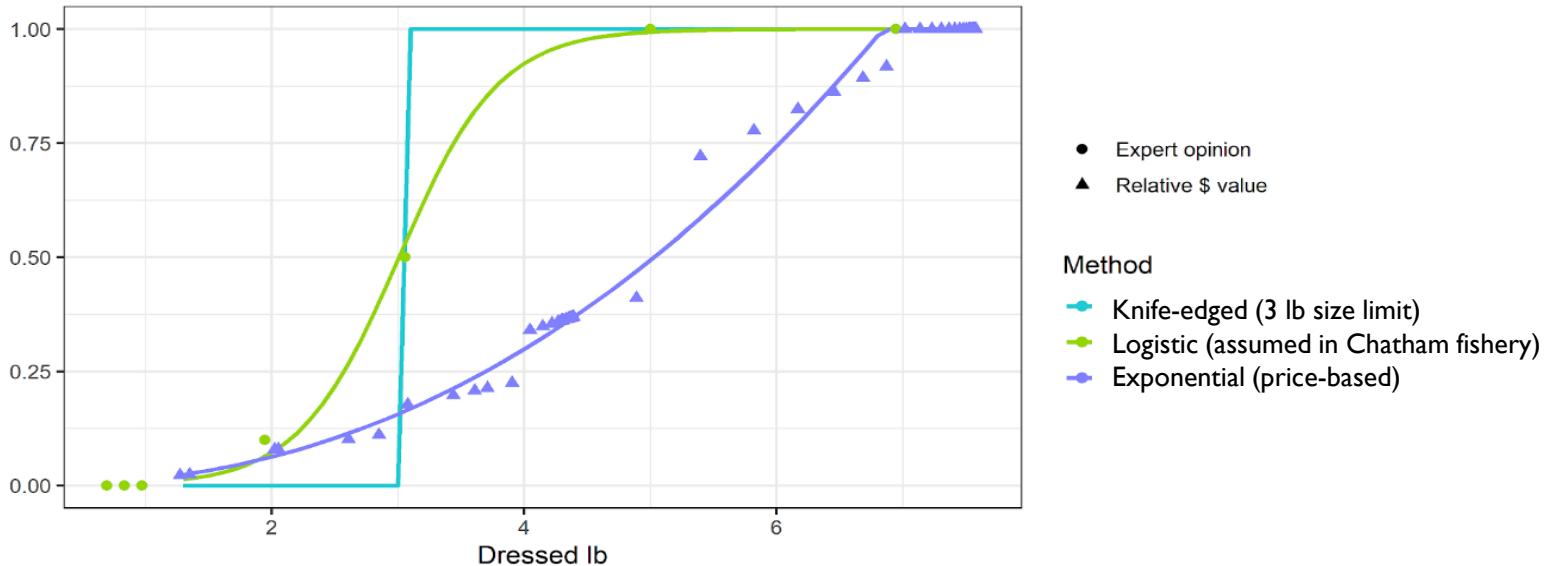

Retention selectivity as a function of sex and age

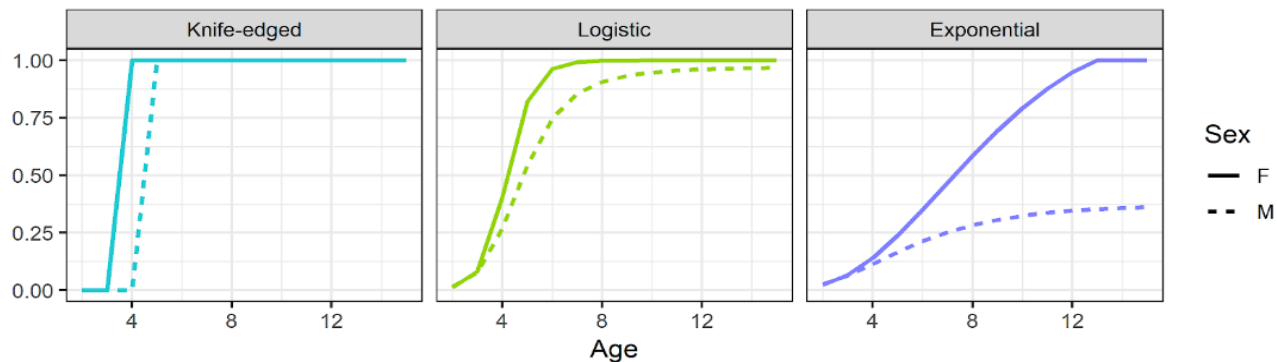

# ELEMENT 3: DISCARD MORTALITY ACCOUNTING

Retention selectivity as a function of dressed weight

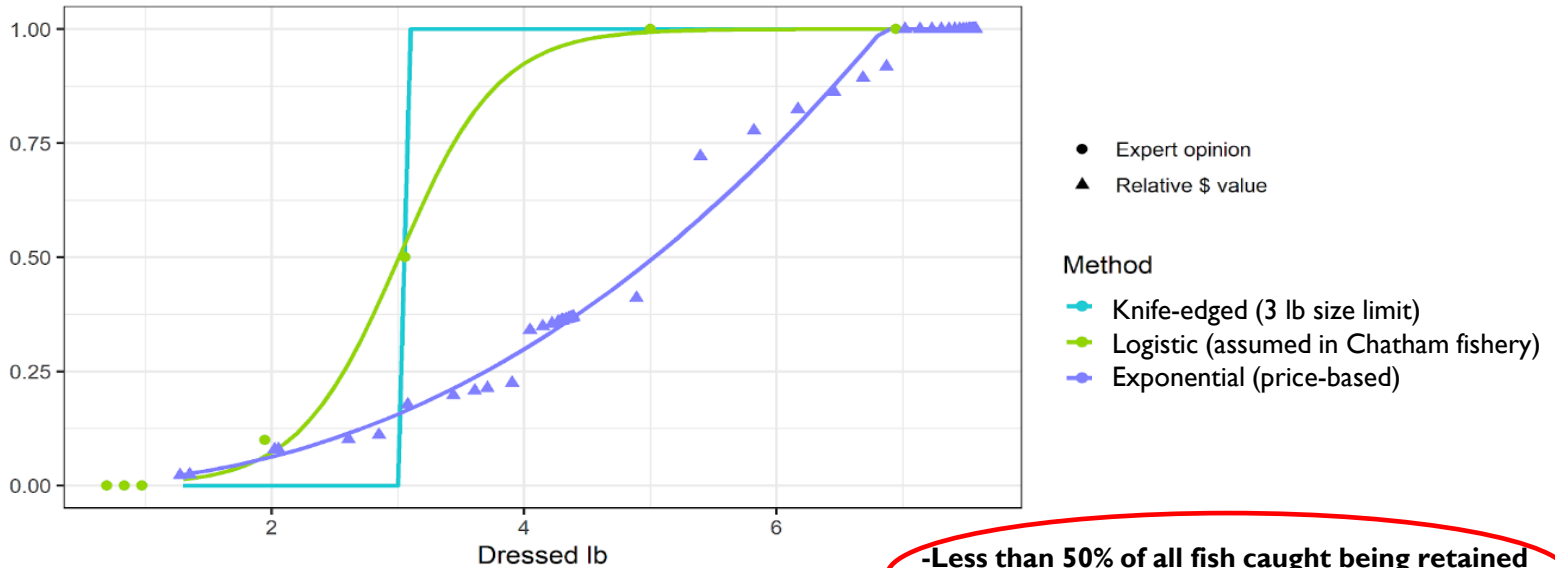

**-Less than 50% of all fish caught being retained**  
**-Highly skewed towards mature females**

Retention selectivity as a function of sex and age

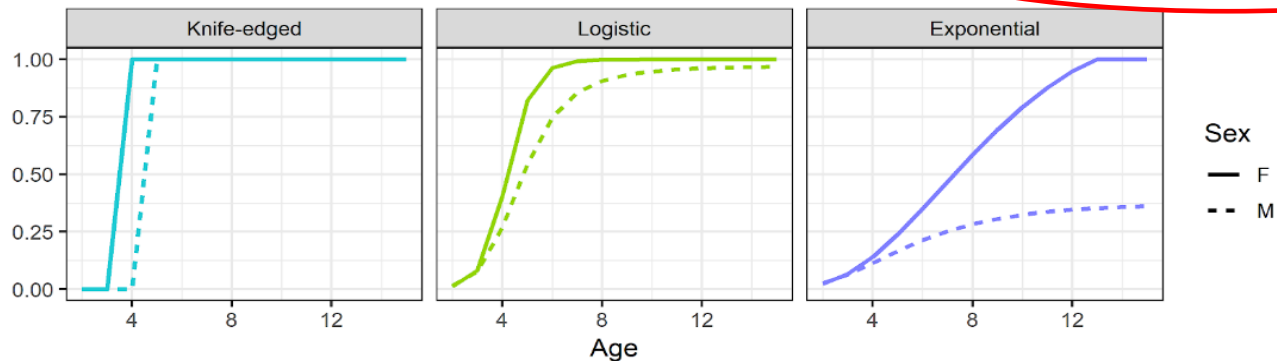

# ELEMENT 3: DISCARD MORTALITY ACCOUNTING

- *Using novel data sources to estimate discards*
  - Shoreside Sampling
  - eLandings fish ticket



<https://www.fishfarmingexpert.com/article/black-cod-could-be-big-in-b-c/>





# ELEMENT 3: DISCARD MORTALITY ACCOUNTING

- *Using novel data sources to estimate discards*
  - ~~Shoreside Sampling~~
  - eLandings fish ticket



<https://www.fishfarmingexpert.com/article/black-cod-could-be-big-in-b-c/>



# ELEMENT 3: DISCARD MORTALITY ACCOUNTING

Processor size grades compositions by fishery

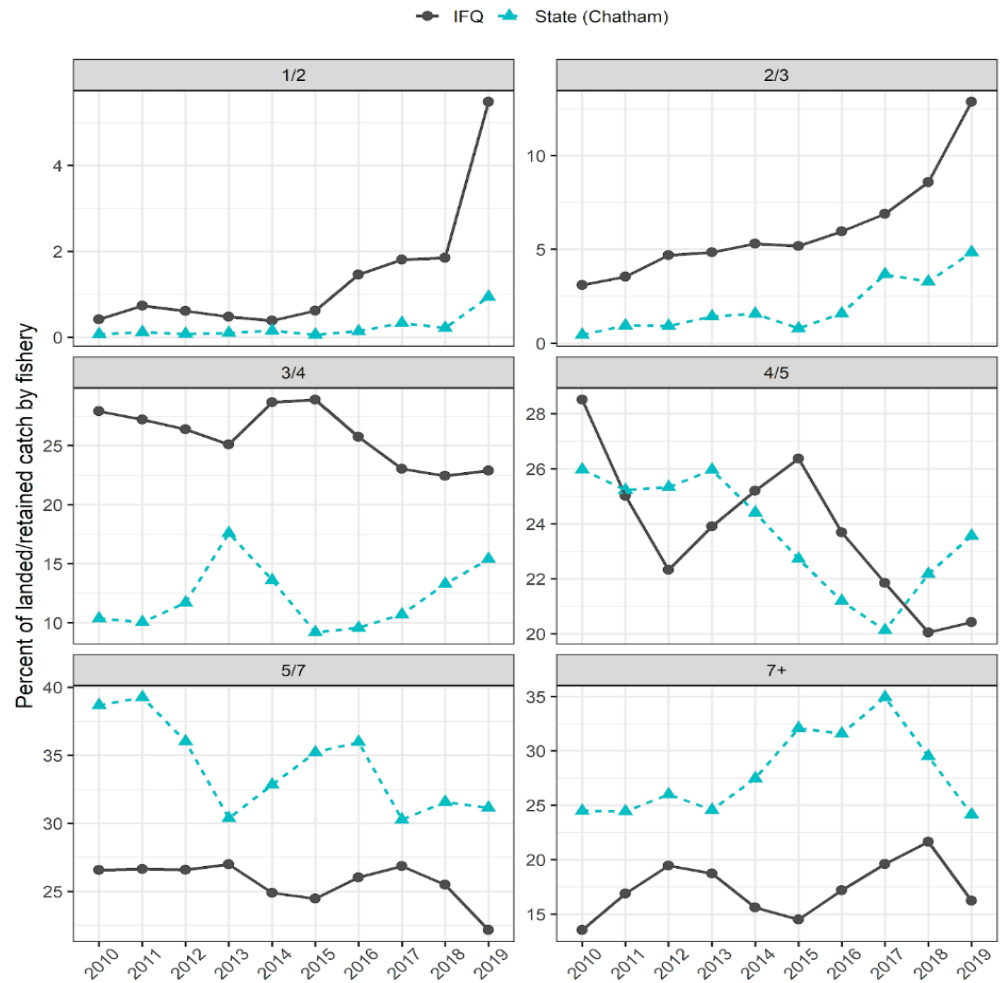

# ELEMENT 3: DISCARD MORTALITY ACCOUNTING

- How discards are incorporated into stock assessment and harvest recommendations

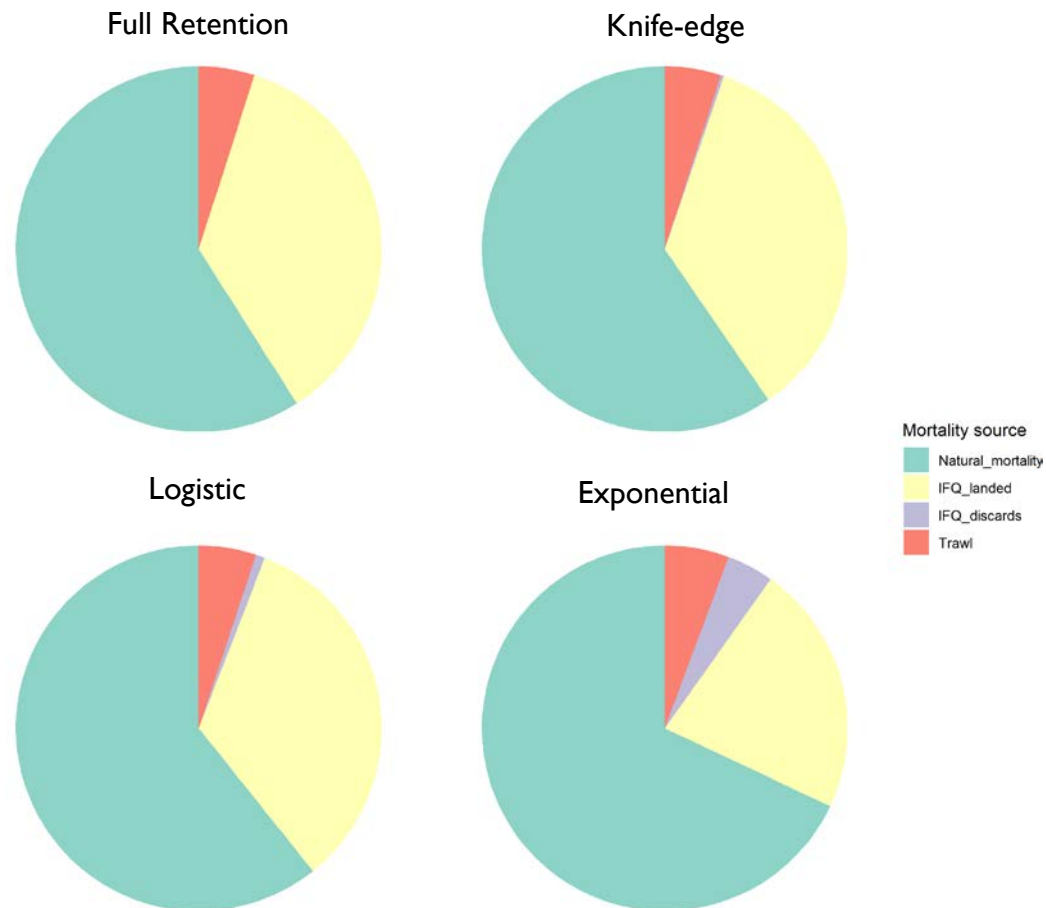

# ELEMENT 3: DISCARD MORTALITY ACCOUNTING

- *Impacts of discarding on sablefish stock status and fishery performance*

## 3. Assessment of the Sablefish Stock in Alaska

Daniel R. Goethel, Dana H. Hanselman, Cara J. Rodgveller, Kari H. Fenske,  
S. Kalei Shotwell, Katy B. Echave, Patrick W. Malecha, Kevin A. Siwicke, and Chris R. Lunsford

November 2020

### Executive Summary

#### Summary of Changes to the Assessment

Relative to last year's assessment, we have not made any major changes in the current assessment except for inclusion of new data. The changes are summarized below.

#### Changes to the Input Data

New data included in the assessment model were relative abundance and length data from the 2020 longline survey, relative abundance and length data from the fixed gear fishery for 2019, length data from the trawl fisheries for 2019, age data from the longline survey and fixed gear fishery for 2019, updated catch for 2019, and projected 2020 - 2022 catches. Estimates of killer and sperm whale depredation in the fishery were updated and projected for 2020 - 2022. In 2020, there was not a NMFS Gulf of Alaska trawl survey.

#### Changes to the Assessment Methodology

There were no changes in the assessment methodology. However, there is an authors' recommended ARC



# ELEMENT 3: DISCARD MORTALITY ACCOUNTING

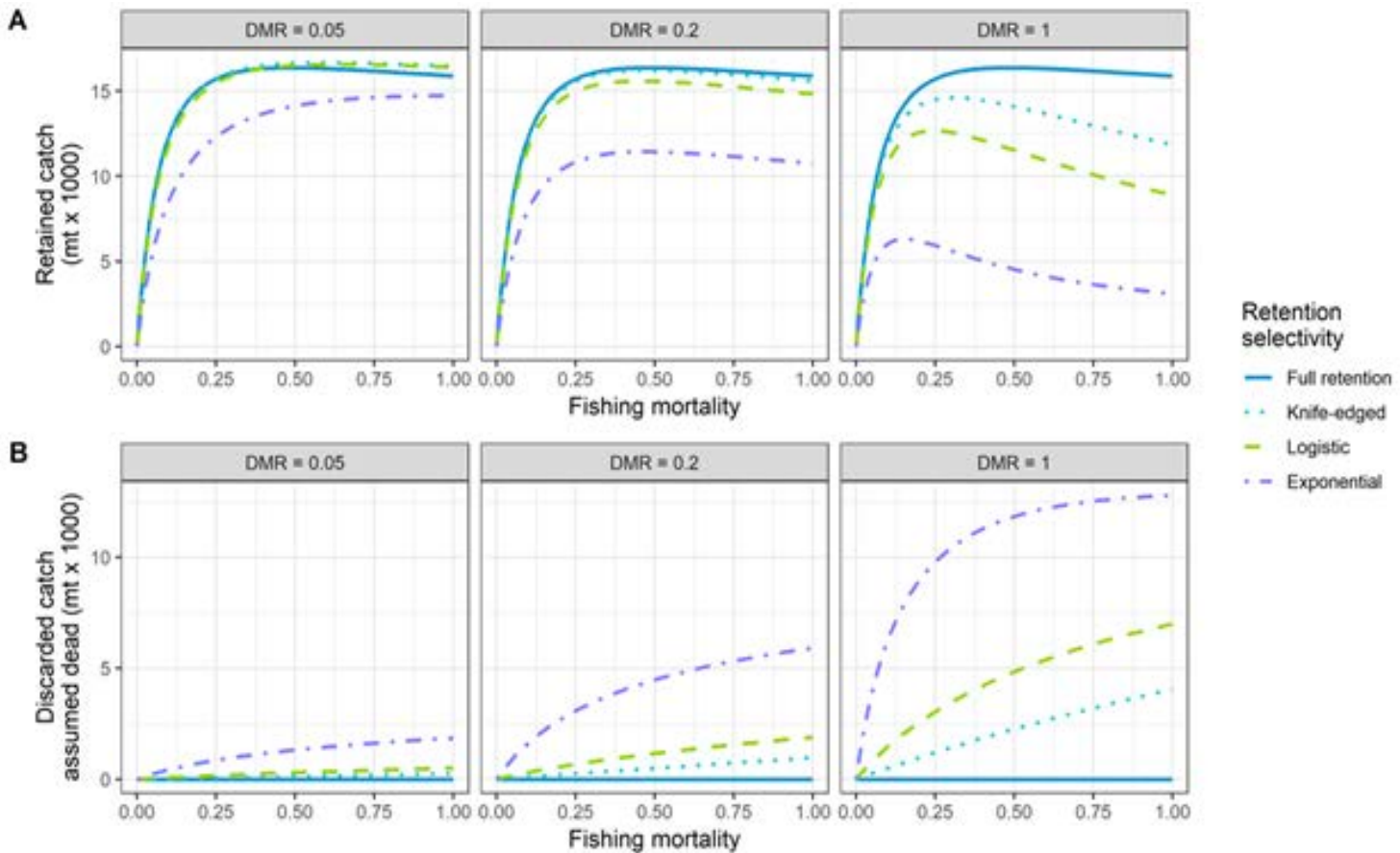

# ELEMENT 3: DISCARD MORTALITY ACCOUNTING

- Yield per recruit model also showed:
  - Discarding will result in a decrease in fishery efficiency (number of retained fish / number of fish captured by gear).
  - Direct fishery value will only increase in some scenarios.



# ELEMENT 4: MONITORING AND ENFORCEMENT

The analysis should describe potential monitoring and enforcement provisions that could improve estimates of voluntary and regulatory discards.

- Implementation needs:
  - Differentiate size composition of released and retained
  - Prevent observer effect
  - Ensure observer safety and work within vessel size constraints
  - Make necessary changes to database





# ELEMENT 4: MONITORING AND ENFORCEMENT

- Potential solution
  - Shore-based sampling

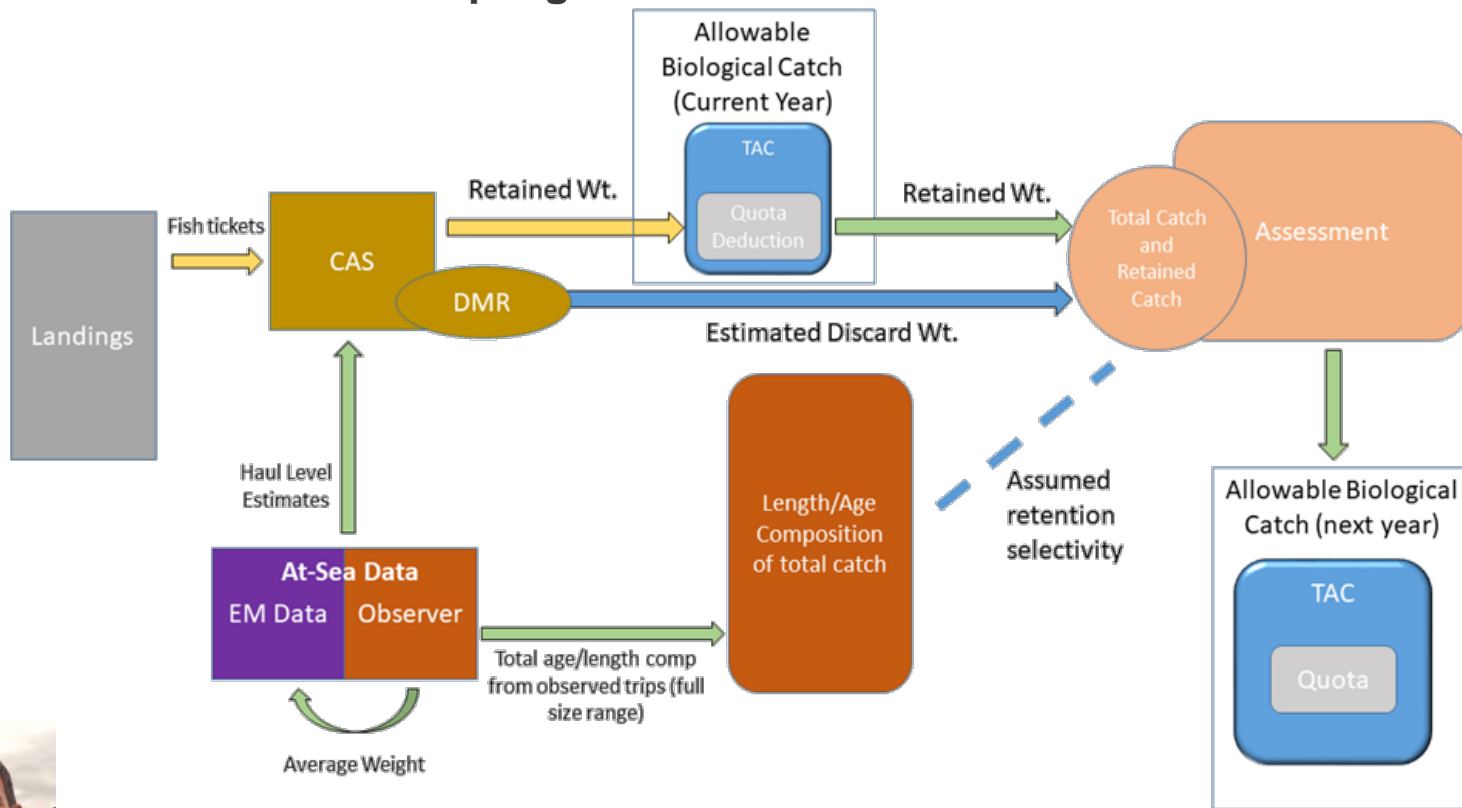

# ELEMENT 4: MONITORING AND ENFORCEMENT

- Potential solution
  - Shore-based sampling

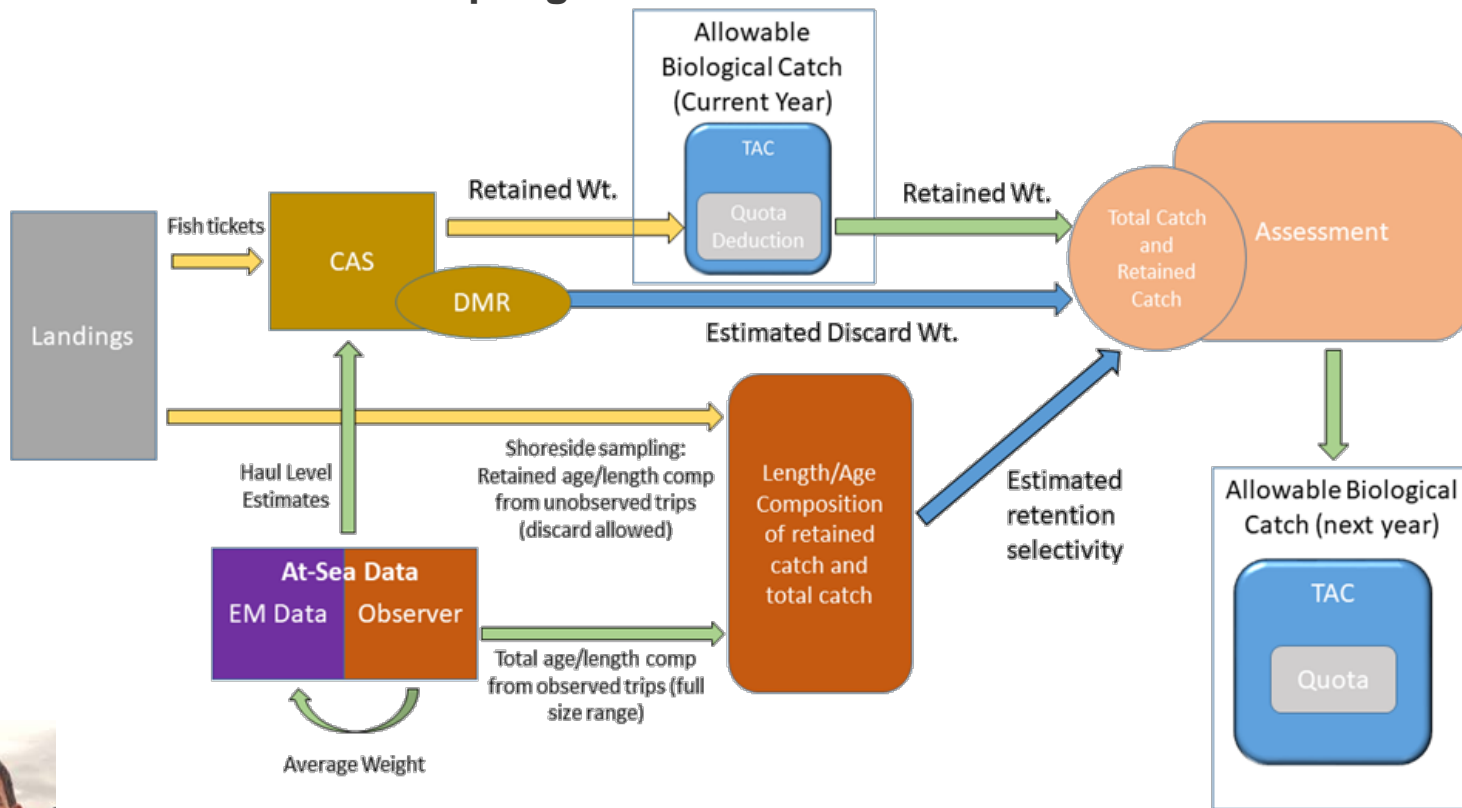

# ELEMENT 4: MONITORING AND ENFORCEMENT

- Potential solution
  - Shore-based sampling

- Challenges
  - Size grading
  - New program \$\$

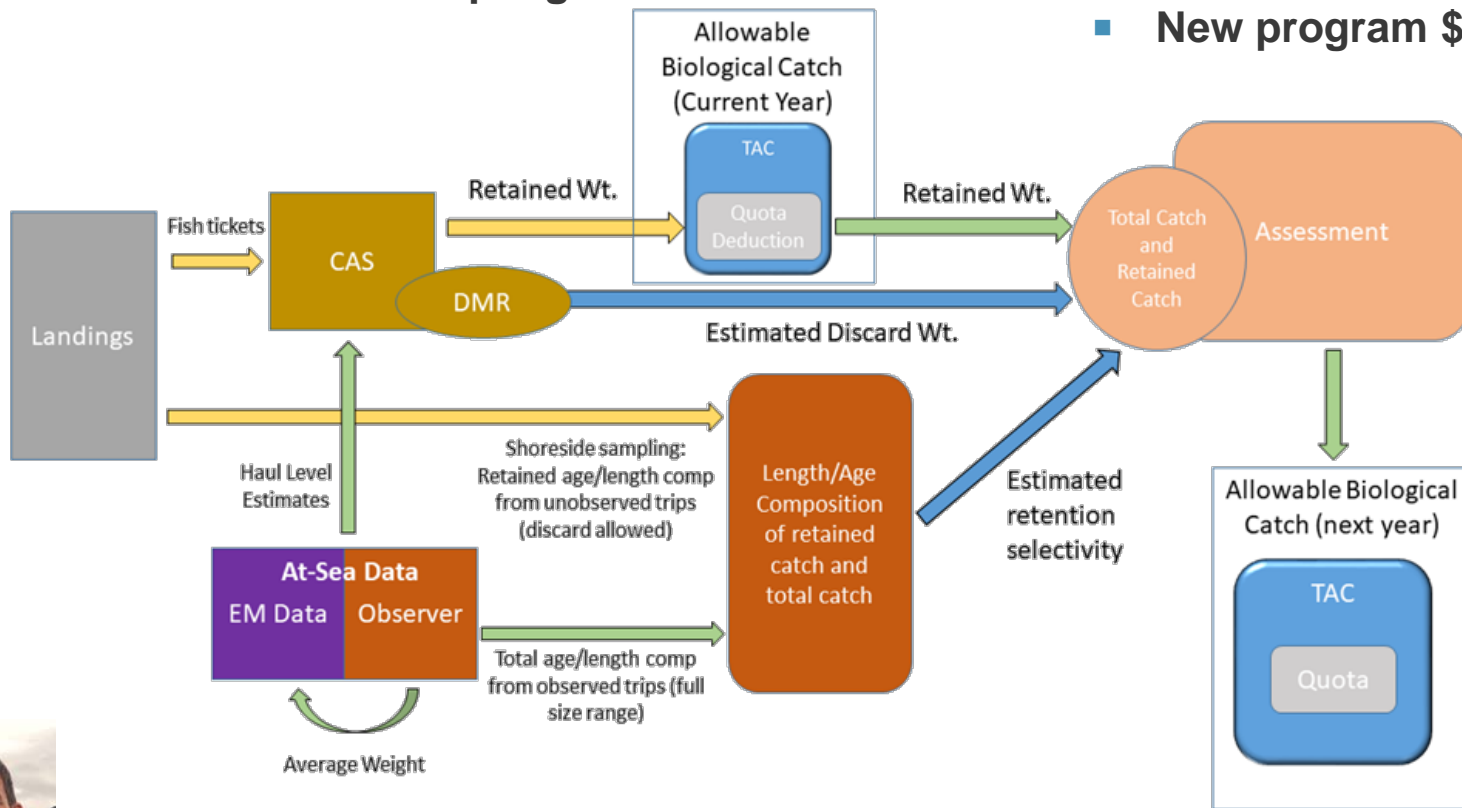

# ELEMENT 4: MONITORING AND ENFORCEMENT

## Full coverage EM



# ELEMENT 4: MONITORING AND ENFORCEMENT

## Full coverage EM

- need observers
- b/c EM can't collect:
  - size
  - sex
  - age
- fishing behavior
- implementation



# ENVIRONMENTAL ASSESSMENT

- Environmental impacts resulting from increased fishing effort.
  - Assume ~21% increase in effort under Alternative 2.
- Seabirds
  - Overall, negligible impacts on take of seabirds.
- Marine Mammals
  - Sperm whales – Could result in additional takes but not expected to have significant impact.
  - Stellar Sea Lions, Killer whales, Humpback whales – Not expected to have significant impact.
  - *Prey Availability and Disturbance Effects*
    - May increase rates of whale depredation.
    - Not likely to have population level effects or disturb marine mammals.



# REGULATORY IMPACT REVIEW

- 4 Regulatory Impact Review
  - 4.1 Statutory Authority
  - 4.2 Purpose and Need for Action
  - 4.3 Alternatives
  - 4.4 Methods
  - 4.5 Description of the Sablefish Fisheries
    - 4.5.1 Management
    - 4.5.2 Sablefish IFQ Fishery →
      - 4.5.2.1 IFQ Prohibition on Discarding
      - 4.5.2.2 Accounting for IFQ discards
      - 4.5.2.3 Sablefish IFQ Gear Types
        - 4.5.2.3.1 Operational costs
      - 4.5.2.4 Sablefish IFQ vessel class categories
      - 4.5.2.5 Sablefish IFQ Landings and Revenue
      - 4.5.2.6 Sablefish IFQ Market Grades and Price/lb
      - 4.5.2.7 Sablefish IFQ Communities
- 4.6 Analysis of Impacts: Alt 1
- 4.7 Analysis of Impacts: Alt 2





# REGULATORY IMPACT REVIEW

## The sablefish fishery off Alaska is in a state of transition

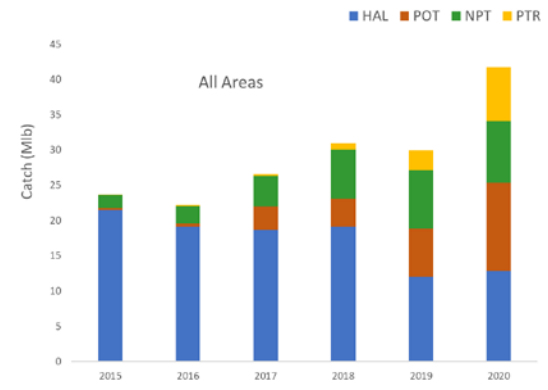
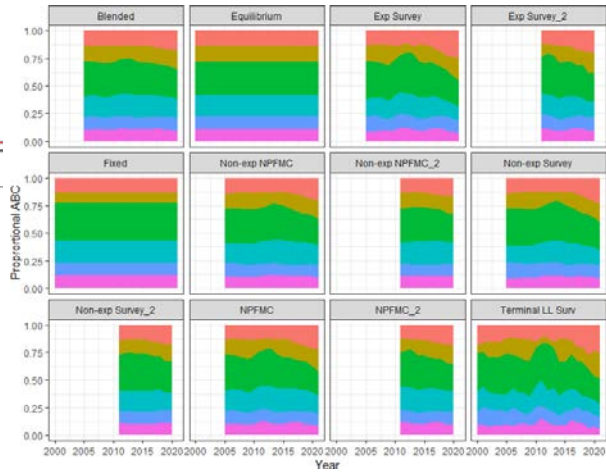
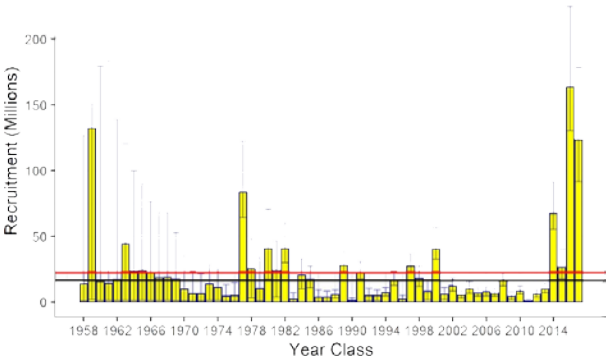
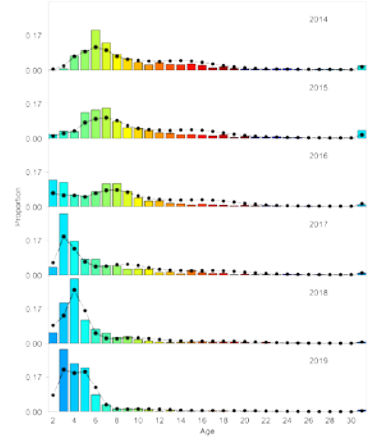
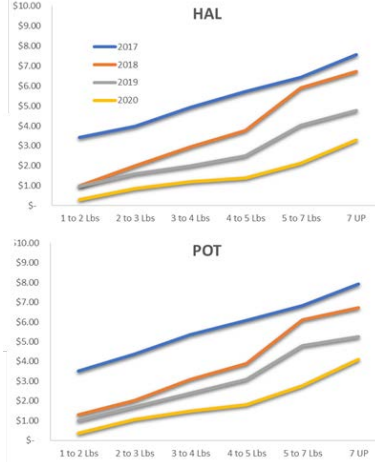
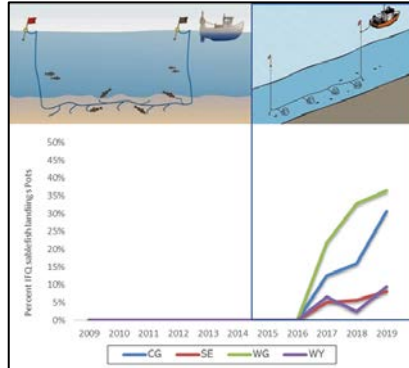

# REGULATORY IMPACT REVIEW

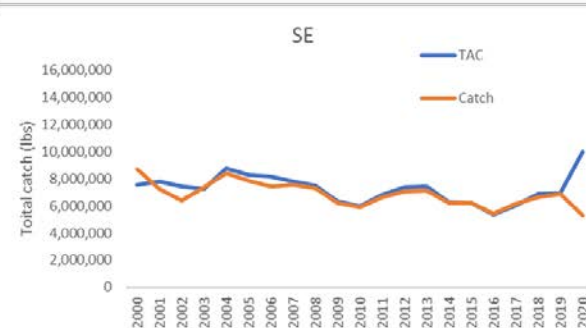
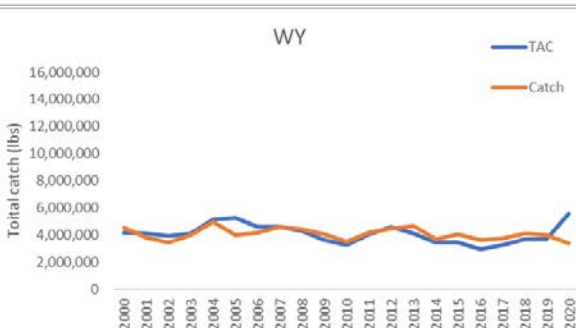
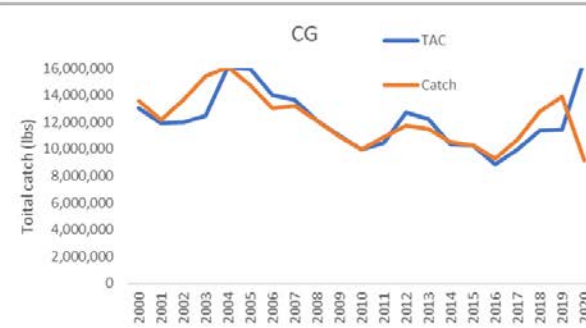
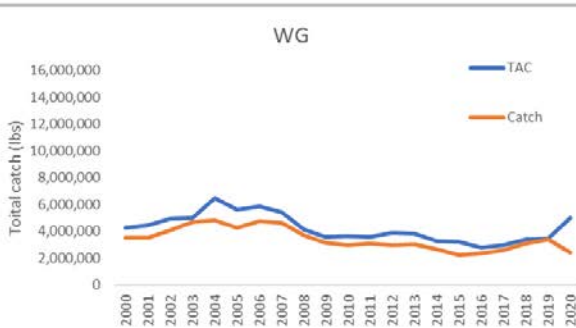
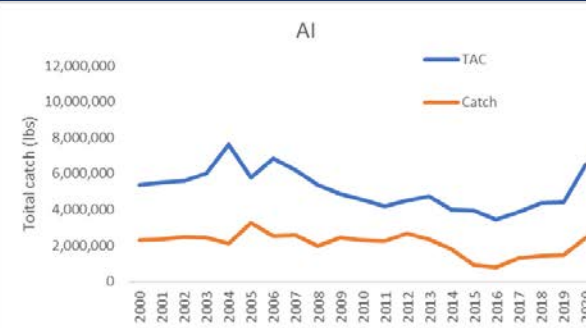
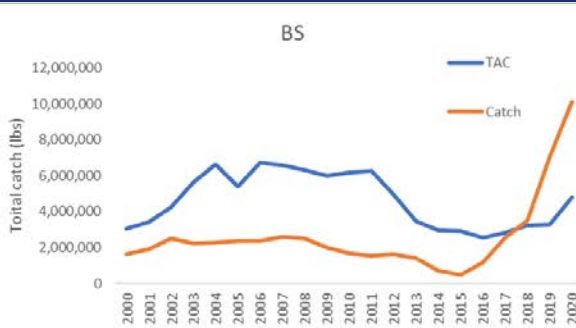

# REGULATORY IMPACT REVIEW

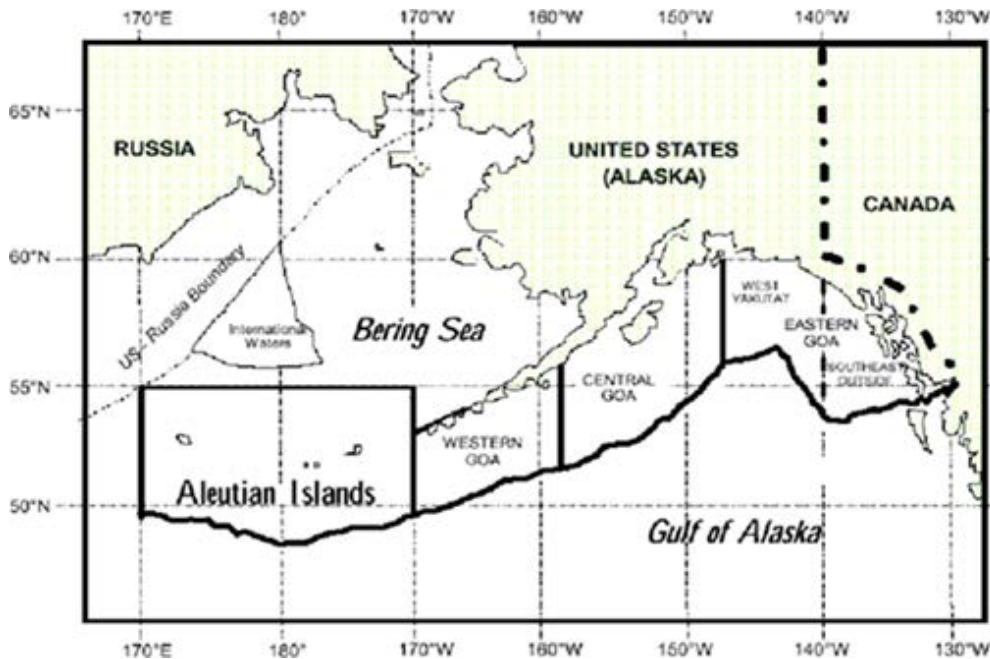

Bering Sea BS  
 Aleutian Islands AI  
 Western Gulf WG  
 Central Gulf CG  
 West Yakutat WY  
 Southeast SE

Eastern Gulf EG  
 includes WY+SE

$$(QS/QSP) \times TAC = IFQ$$

Area	Quota Share Pool
BS	18,765,280
AI	31,932,492
WG	36,029,579
CG	111,686,622
WY	53,266,430
SE	66,120,619

**TOTAL** 317,801,022



# REGULATORY IMPACT REVIEW

## Prohibition on releasing sablefish

- Initial IFQ not large enough for full-time directed fishery for halibut or sablefish
  - Fishermen would have an incentive to *discard* bycatch of IFQ species.
  - To prevent this, ... prohibit the *discard* of IFQ halibut or sablefish
- Releasing small, unmarketable sablefish in a full-time directed fishery would be economic discards, i.e., *highgrading*
- This is currently illegal but would be permissible under the action.
- Intent of action is for release to be limited to only the smallest fish in the catch



# REGULATORY IMPACT REVIEW

## Accounting for releases

- Fixed gear sablefish TACs are fully allocated to the IFQ Program
- Overages in the fixed gear allocation of the TAC were intended to be absorbed by the trawl gear allocation
- If the trawl sector catches its TAC, no buffer for fixed gear discards
- No proposed limit on releases
- If release is accommodated within ABC (Element 3), TACs would be reduced proportionately
  - Deduction affects all QS holders proportionately



# REGULATORY IMPACT REVIEW

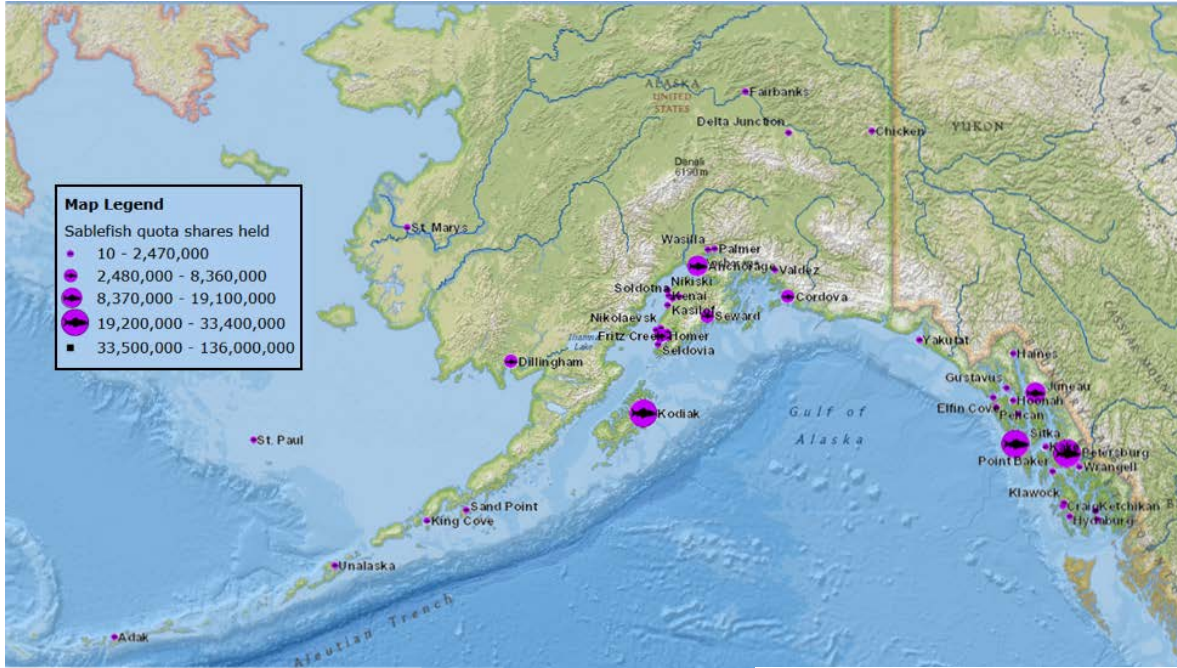

Vessel Class

Area	Vessel Class		
	A	B	C
BS	30	52	39
AI	33	50	31
WG	47	95	74
CG	51	205	291
WY	33	129	174
SE	44	102	432





# REGULATORY IMPACT REVIEW

## Total Revenue

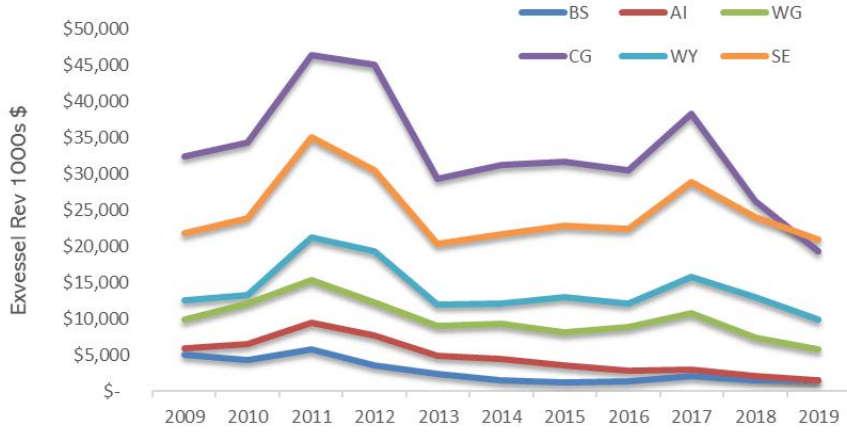

## BSAI

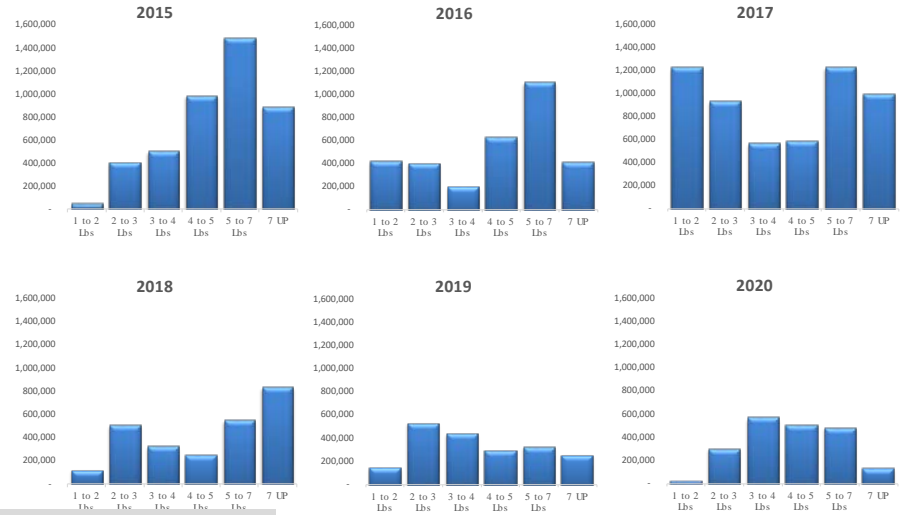

## WG

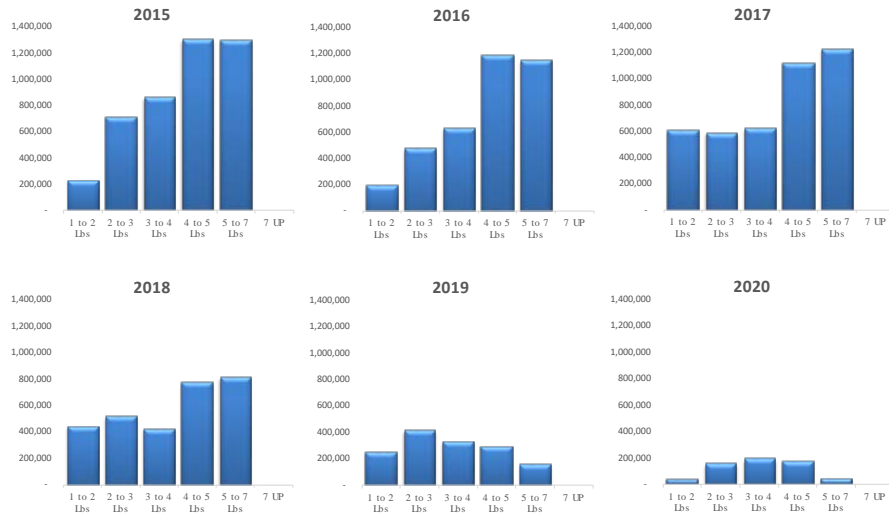

## Market Grade Revenue



# REGULATORY IMPACT REVIEW

## Total Revenue

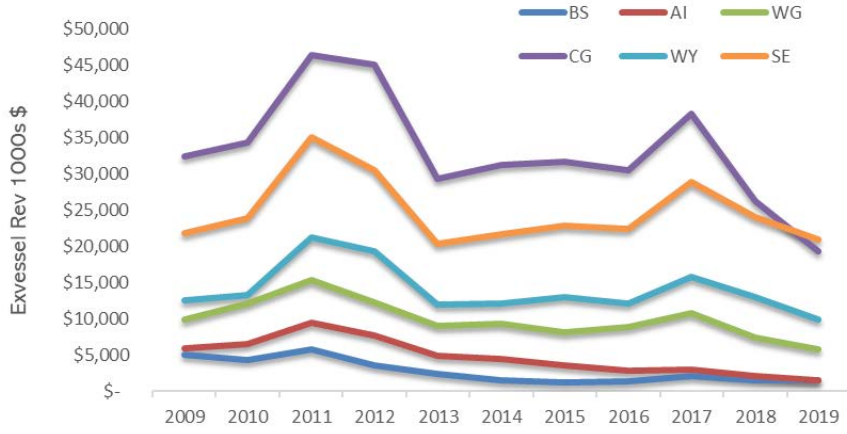

## CG

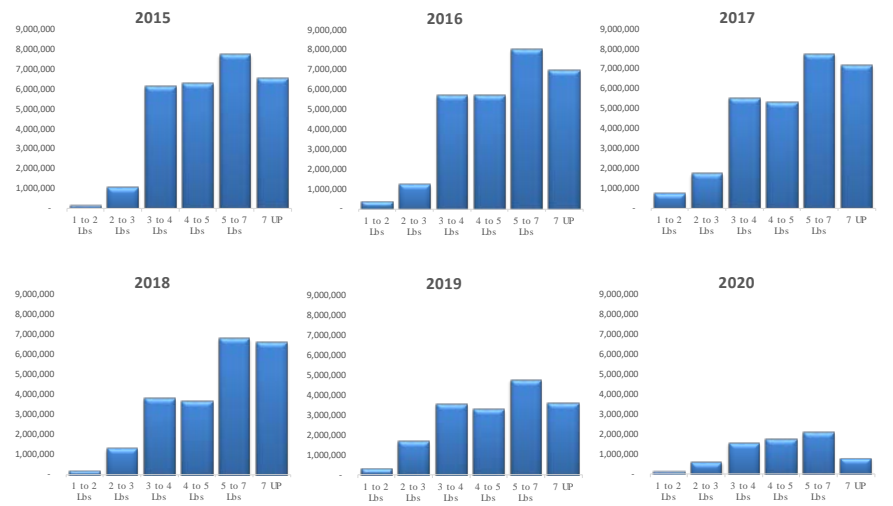

## EG



## Market Grade Revenue





# REGULATORY IMPACT REVIEW

## Price Gradients

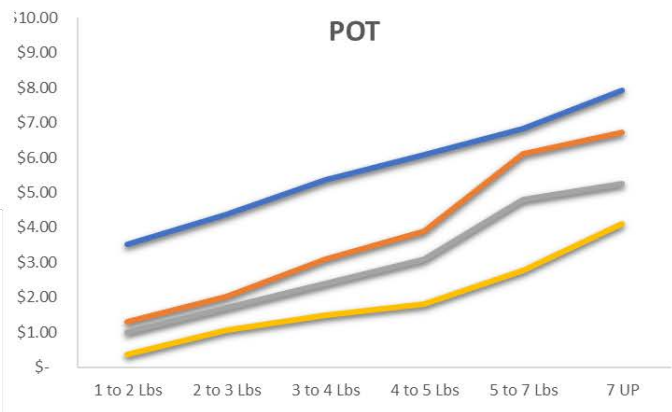
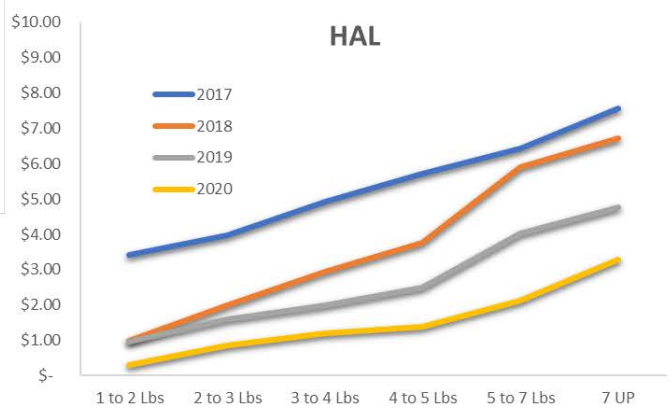
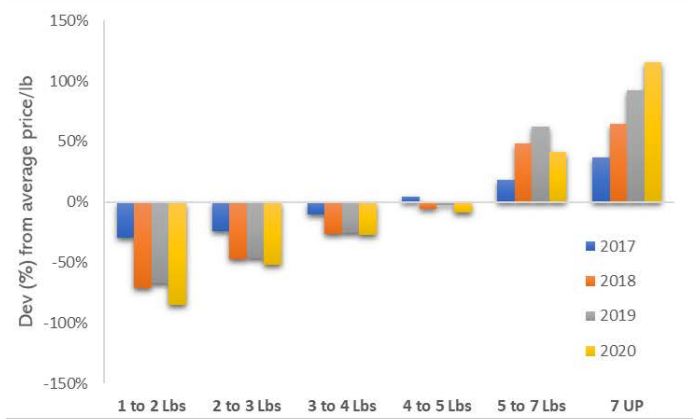

# REGULATORY IMPACT REVIEW

## Price Gradients

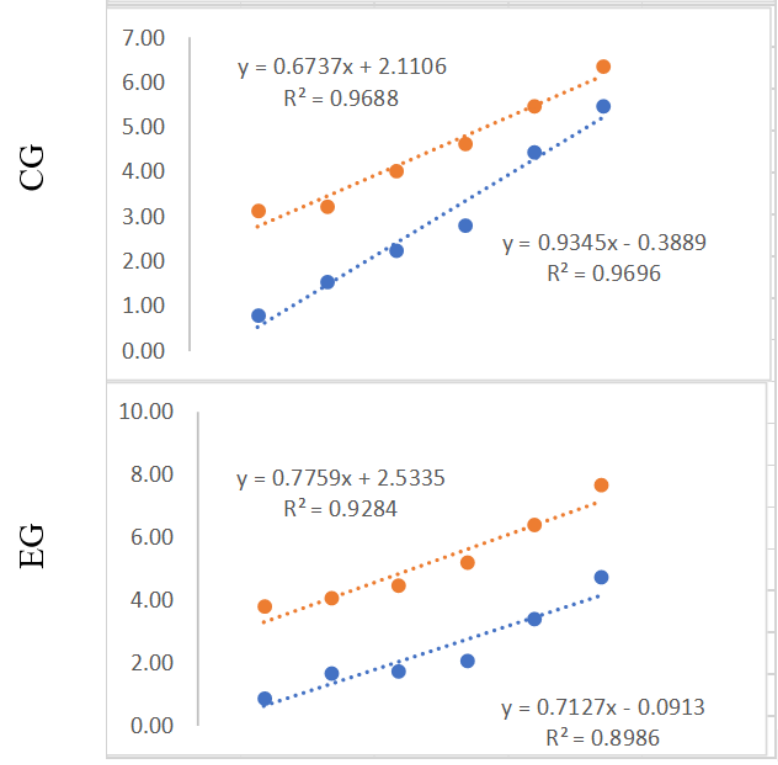
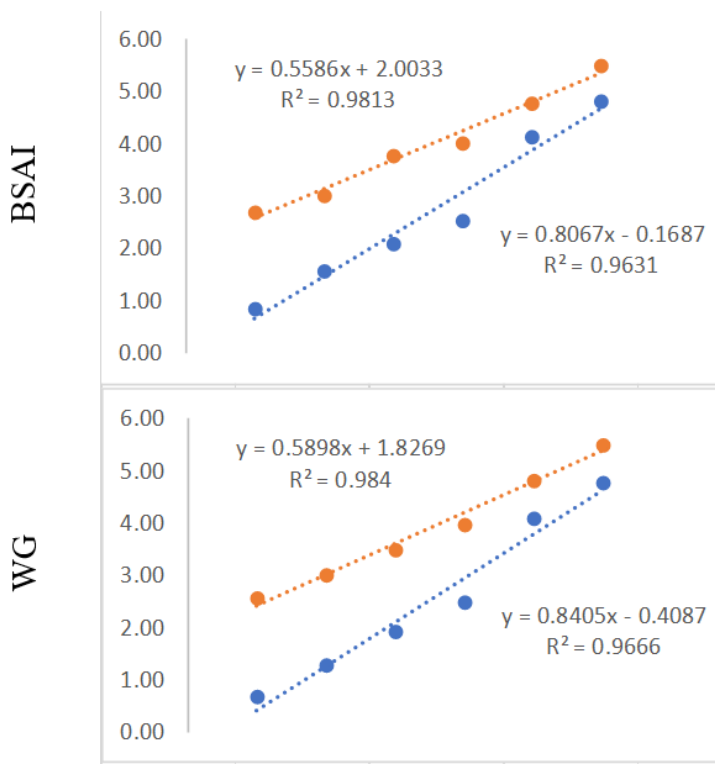

# REGULATORY IMPACT REVIEW

## Impacts of Alternatives

- Alternative 1
  - All impacts occur within the context of market fluctuations
    - Harvesters – continued negative impacts of regulations on value of catch
    - Processors – reduced value and size of deliveries
    - Communities – varies with dependency and engagement



# REGULATORY IMPACT REVIEW

## Impacts of Alternatives

- Alternative 2
  - All impacts occur within the context of greatly reduced market value
    - Harvesters and Processors – impacts to value of catches and deliveries
      - Highly dependent on magnitude of reduction
        - Positive impacts depend on ability to mitigate loss in IFQ with catches of higher value fish
          - Improbable at higher ABC reductions
          - Negative impacts if unable
          - Strong possibility geographic bias, negative impacts to BSAI operations
    - Communities – variable with dependency and engagement
      - Geographic bias, but reduced dependency lessens magnitude of impacts to minor
    - Trawl fleet
      - Negative to highly negative
      - TAC Options?



# NMFS MANAGEMENT AND ENFORCEMENT

- Management Considerations
  - NMFS has concerns about inability to accurately estimate discards.
  - NMFS is developing techniques that could help but work is still on-going.
- Enforcement Considerations
  - Extension of careful release requirements.
  - Presented to Enforcement Committee ahead of this meeting.
  - No substantive enforcement concerns related to this action.





Questions?



END OF PRESENTATION  
SUPPLEMENTAL SLIDES FOLLOW



# ELEMENT 3: DISCARD MORTALITY ACCOUNTING

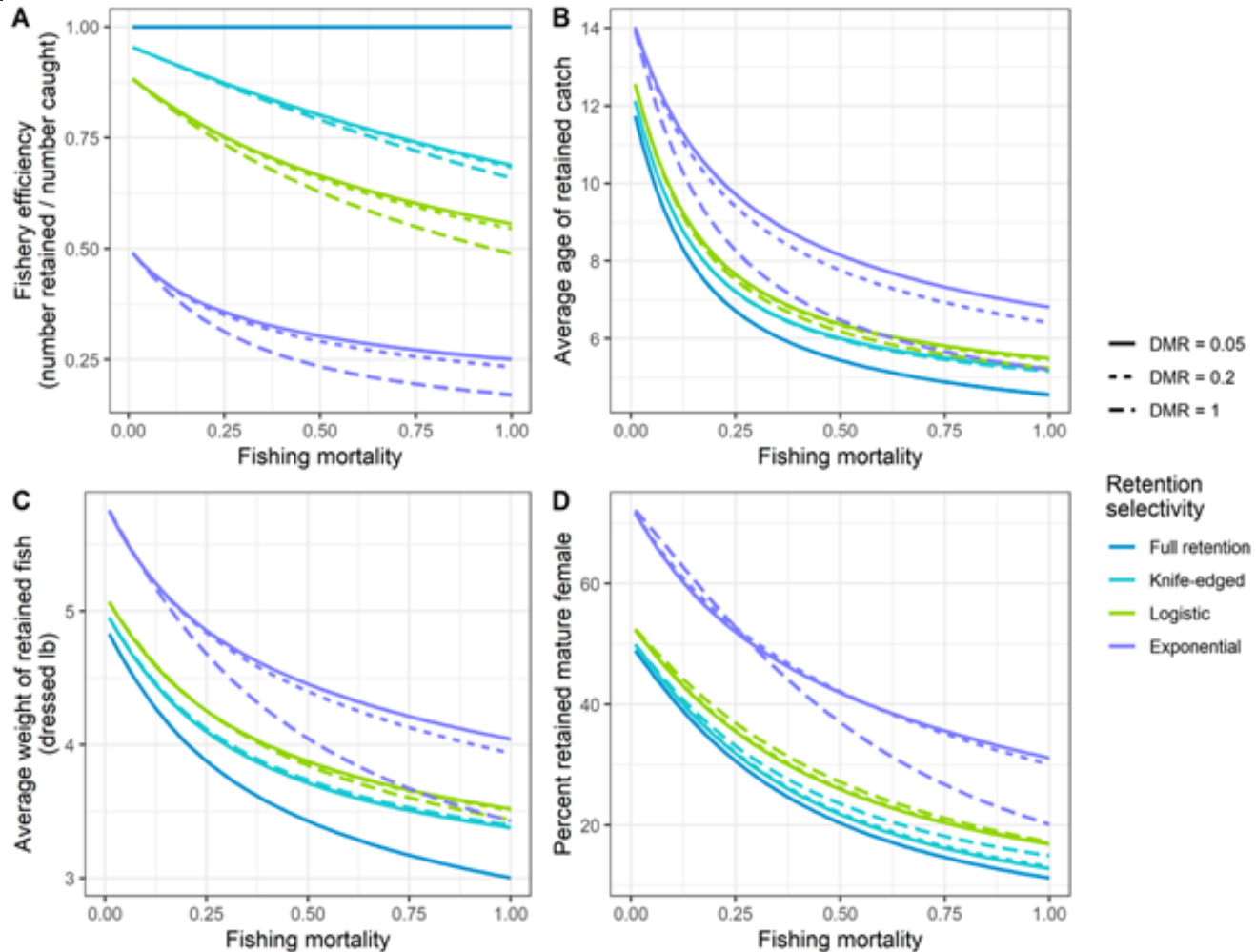



# ELEMENT 3: DISCARD MORTALITY ACCOUNTING

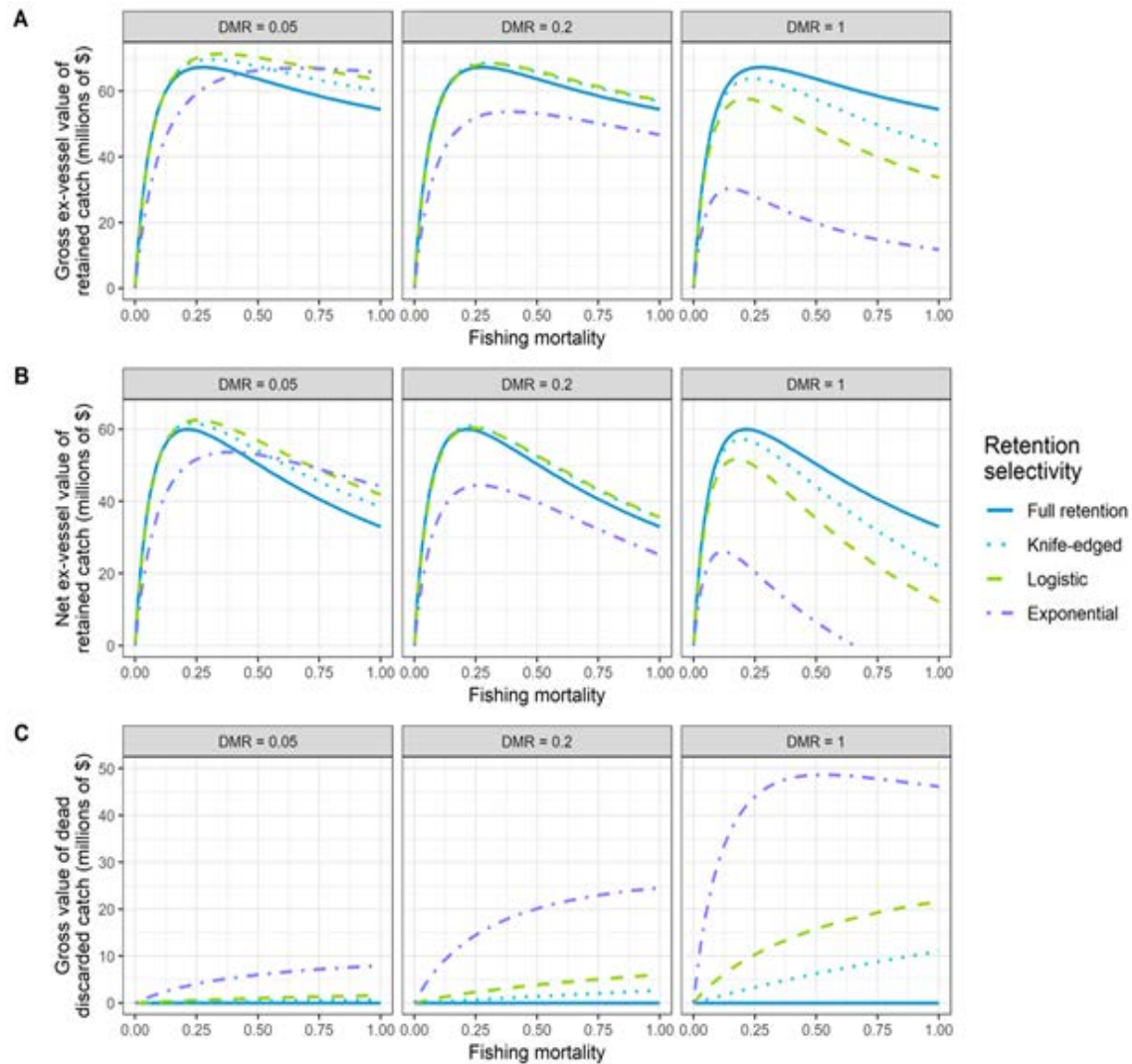

# APPENDIX C: DISCARD SCENARIOS

BSAI	2018-2020				Discard 1-2Lbs		Discard 1-3Lbs		Discard 1-4Lbs	
	Pct Mkt Grade	Price/lb	Landings (lb)	Value	Catch (lb)	Value	Catch (lb)	Value	Catch (lb)	Value
1 to 2 Lbs	12%	\$ 0.82	1,075	\$ 879	1,123	\$ 918	1,419	\$ 1,160	1,952	\$ 1,596
2 to 3 Lbs	30%	\$ 1.54	2,671	\$ 4,110	2,790	\$ 4,293	3,526	\$ 5,425	4,852	\$ 7,464
3 to 4 Lbs	23%	\$ 2.08	2,043	\$ 4,258	2,134	\$ 4,448	2,697	\$ 5,621	3,711	\$ 7,733
4 to 5 Lbs	15%	\$ 2.54	1,319	\$ 3,344	1,378	\$ 3,493	1,741	\$ 4,415	2,395	\$ 6,074
5 to 7 Lbs	12%	\$ 4.14	1,053	\$ 4,358	1,100	\$ 4,552	1,390	\$ 5,752	1,913	\$ 7,915
7 UP	8%	\$ 4.81	753	\$ 3,625	787	\$ 3,787	994	\$ 4,785	1,368	\$ 6,584
<b>Total</b>			8,914	\$20,573	<b>9,312</b>	\$20,573	<b>11,768</b>	\$20,573	<b>16,191</b>	\$20,573
			<b>Adjusted landings and effort(%)</b>		<b>8,189</b>	4.5%	<b>6,822</b>	32.0%	<b>5,676</b>	81.6%
			<b>Discards</b>		1,123		4,945		10,515	

WG	2018-2020				Discard 1-2Lbs		Discard 1-3Lbs		Discard 1-4Lbs	
	Pct Mkt Grade	Price/lb	Landings (lb)	Value	Catch (lb)	Value	Catch (lb)	Value	Catch (lb)	Value
1 to 2 Lbs	5%	\$ 0.68	540	\$ 364	547	\$ 370	627	\$ 424	860	\$ 581
2 to 3 Lbs	23%	\$ 1.29	2,514	\$ 3,238	2,550	\$ 3,284	2,922	\$ 3,764	4,005	\$ 5,158
3 to 4 Lbs	29%	\$ 1.90	3,154	\$ 5,990	3,199	\$ 6,076	3,667	\$ 6,963	5,025	\$ 9,543
4 to 5 Lbs	21%	\$ 2.49	2,341	\$ 5,820	2,375	\$ 5,903	2,722	\$ 6,766	3,730	\$ 9,272
5 to 7 Lbs	14%	\$ 4.09	1,567	\$ 6,408	1,590	\$ 6,500	1,822	\$ 7,450	2,497	\$10,209
7 UP	8%	\$ 4.76	828	\$ 3,940	839	\$ 3,996	962	\$ 4,580	1,318	\$ 6,277
<b>Total</b>			10,943	\$25,759	<b>11,100</b>	\$25,759	<b>12,722</b>	\$25,759	<b>17,435</b>	\$25,759
			<b>Adjusted landings and effort(%)</b>		<b>10,552</b>	1.4%	<b>9,172</b>	16.3%	<b>12,570</b>	59.3%
			<b>Discards</b>		547		3,549		4,864	



# APPENDIX C: DISCARD SCENARIOS

CG	2018-2020				Discard 1-2Lbs		Discard 1-3Lbs		Discard 1-4Lbs	
	Pct Mkt Grade	Price/lb	Landings (lb)	Value	Catch (lb)	Value	Catch (lb)	Value	Catch (lb)	Value
1 to 2 Lbs	5%	\$ 0.80	634	\$ 507	644	\$ 515	700	\$ 560	897	\$ 718
2 to 3 Lbs	15%	\$ 1.53	1,809	\$ 2,774	1,835	\$ 2,815	1,996	\$ 3,062	2,558	\$ 3,923
3 to 4 Lbs	27%	\$ 2.21	3,136	\$ 6,944	3,183	\$ 7,046	3,462	\$ 7,664	4,435	\$ 9,820
4 to 5 Lbs	21%	\$ 2.82	2,481	\$ 6,999	2,518	\$ 7,102	2,739	\$ 7,725	3,509	\$ 9,898
5 to 7 Lbs	20%	\$ 4.46	2,308	\$ 10,288	2,342	\$ 10,439	2,547	\$ 11,355	3,264	\$ 14,549
7 UP	12%	\$ 5.47	1,354	\$ 7,399	1,374	\$ 7,508	1,494	\$ 8,166	1,914	\$ 10,463
<b>Total</b>			11,722	\$ 34,910	<b>11,895</b>	\$ 34,910	<b>12,938</b>	\$ 34,910	<b>16,578</b>	\$ 34,910
			<b>Adjusted landings and effort(%)</b>		<b>11,251</b>	1.5%	<b>10,242</b>	10.4%	<b>13,123</b>	41.4%
			<b>Discards</b>		644		2,697		3,455	

EG	2018-2020				Discard 1-2Lbs		Discard 1-3Lbs		Discard 1-4Lbs	
	Pct Mkt Grade	Price/lb	Landings (lb)	Value	Catch (lb)	Value	Catch (lb)	Value	Catch (lb)	Value
1 to 2 Lbs	2%	\$ 0.86	237	\$ 204	238	\$ 205	251	\$ 216	289	\$ 249
2 to 3 Lbs	9%	\$ 1.64	1,059	\$ 1,733	1,065	\$ 1,744	1,123	\$ 1,839	1,293	\$ 2,118
3 to 4 Lbs	21%	\$ 1.71	2,457	\$ 4,211	2,472	\$ 4,236	2,606	\$ 4,466	3,002	\$ 5,145
4 to 5 Lbs	21%	\$ 2.07	2,442	\$ 5,063	2,456	\$ 5,094	2,590	\$ 5,370	2,983	\$ 6,185
5 to 7 Lbs	23%	\$ 3.43	2,670	\$ 9,154	2,686	\$ 9,210	2,832	\$ 9,710	3,262	\$ 11,184
7 UP	24%	\$ 4.70	2,872	\$ 13,514	2,890	\$ 13,596	3,047	\$ 14,334	3,509	\$ 16,510
<b>Total</b>			11,737	\$ 33,880	<b>11,808</b>	\$ 33,880	<b>12,449</b>	\$ 33,880	<b>14,339</b>	\$ 33,880
			<b>Adjusted landings and effort(%)</b>		<b>11,570</b>	0.6%	<b>11,075</b>	6.1%	<b>12,756</b>	22.2%
			<b>Discards</b>		238		1,374		1,583	

