



EFP Update: Trident Pollock Trawl Modified Footrope Project

Noëlle Yochum & Shannon Carroll

June 2026 NPFMC – D1 Pelagic Trawl Research
3,6 June 2026

**Note: To view the video content in this presentation, see
the YouTube recording at www.youtube.com/@npfmc.**



Acknowledging
the time and
commitment to
this project by
our captains and
crew, and to
Swan Net USA



Measuring Seafloor Contact & Trawl Design



- Terms and concepts that we will be discussing
- Context for the focus on gear development



Measuring Seafloor Contact

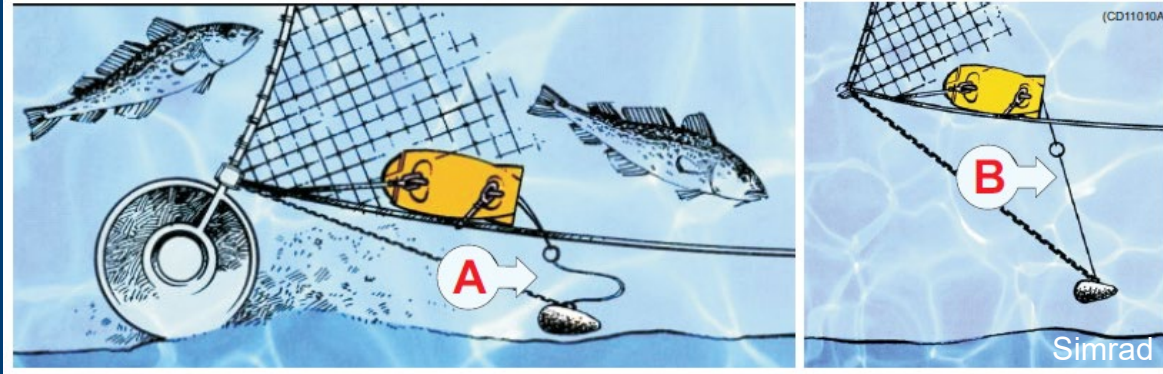

On or off bottom

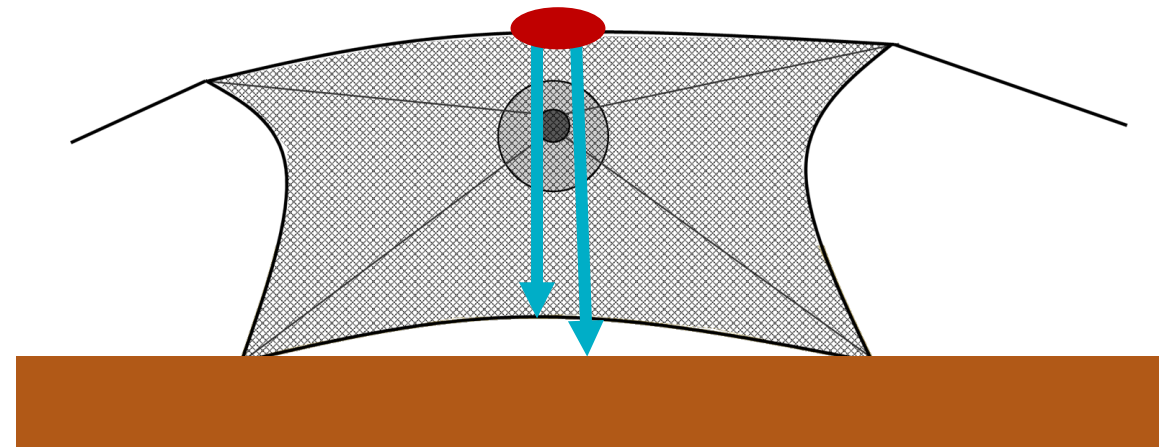
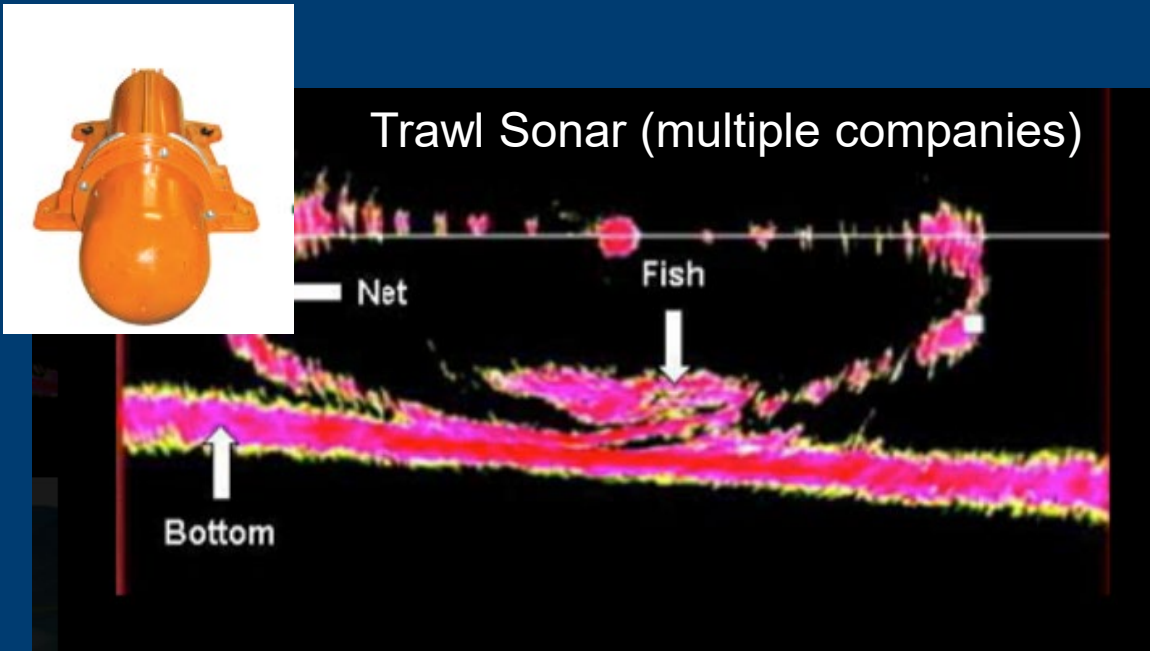

Clearance

Measuring Seafloor Contact

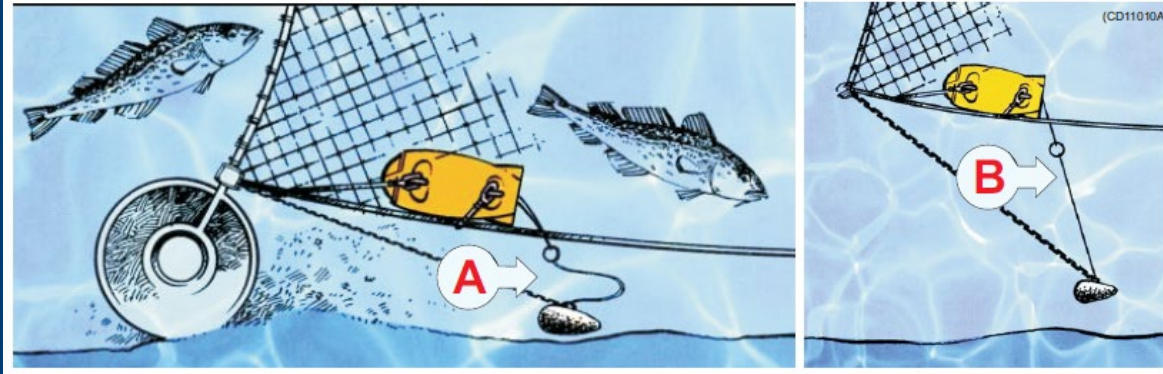

- Variability in contact (by location and over the duration of tow)
- On/off bottom only; no clearance measure
 - Need gear near the seafloor when pollock are on bottom
- Instruments on the footrope are challenged by a lack of placement locations; and needing to go over the net reel or be removed/attached with each tow



Measuring Seafloor Contact

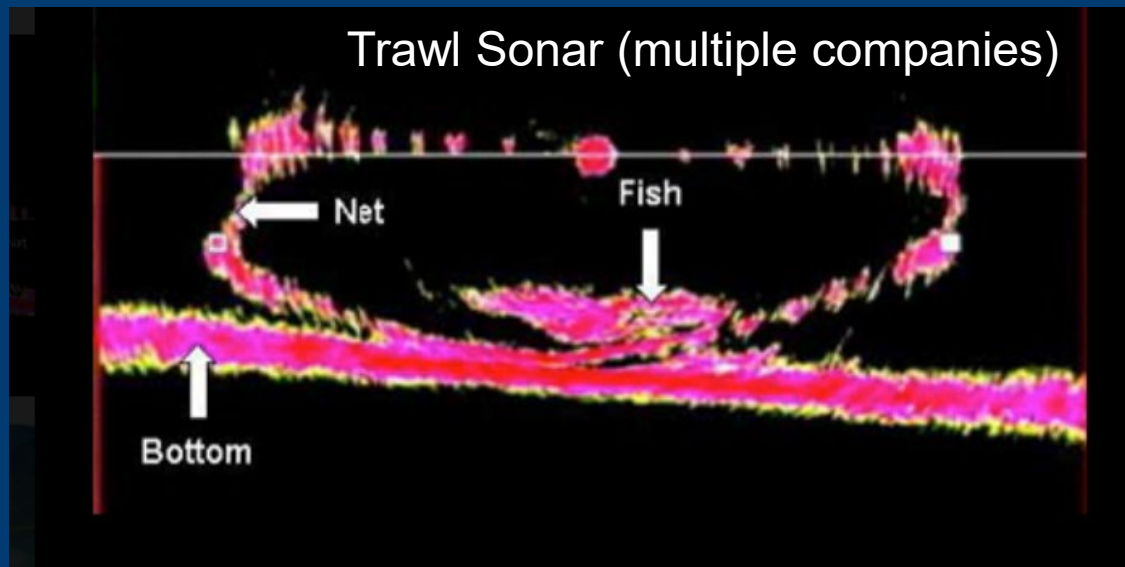

- Instruments on the headrope cannot accurately measure contact and clearance between the footrope and seafloor when near the seafloor
- Sensors are susceptible to limitations caused by wavelength and frequency (and other) factors leading to significant error margins due to wave absorption and substrate disruptions



Measuring Seafloor Clearance

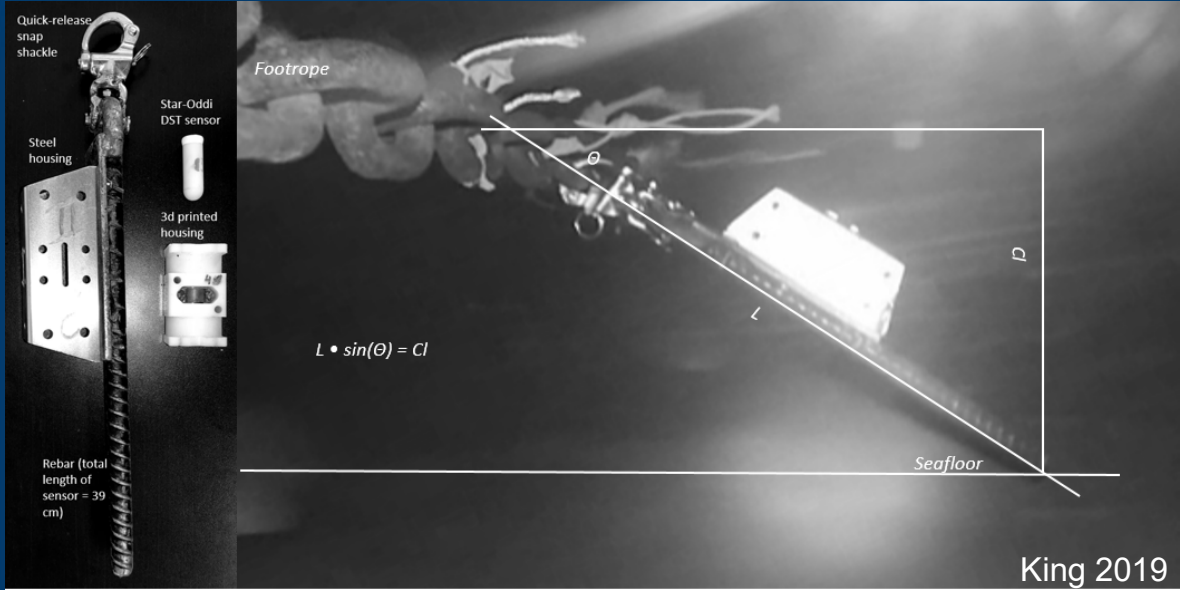



Measuring Seafloor Clearance

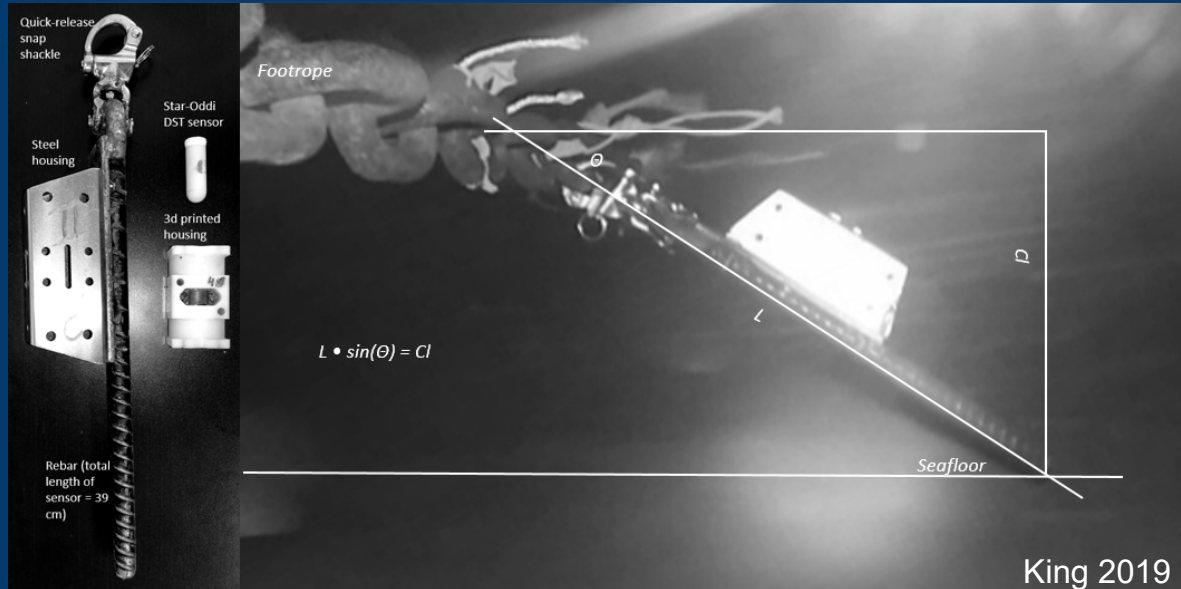

- Attachments can bind up
- Clearance measurement limited by length of the rebar
- BCS data largely seen as unreliable due to errors in the data (e.g., sensor binding up, influence by external factors such as water currents, net speed, and debris causing variations in angle measurements), the need to smooth the data
- Data processing is time intensive
- Durability is needed for repeated deployments
- Need to remove and attach due to the net reel



Measuring Seafloor Clearance

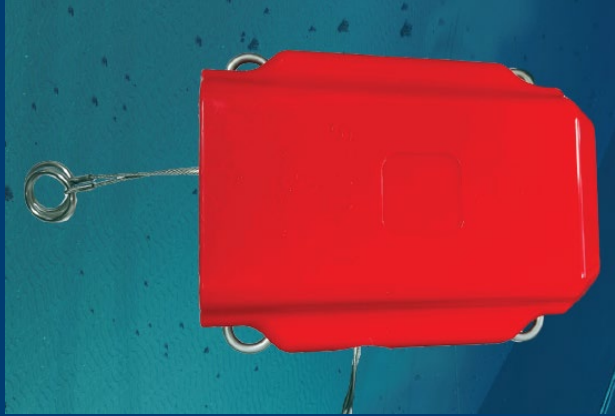

- Acoustics have a “dead zone” where measurements cannot be provided within the critical 1-meter range needed for detailed bottom-clearance
- Instruments on the footrope are challenged by a lack of placement locations; needing to go over the net reel or be removed/attached with each tow



Fig. 1. Illustration of conceptual model of walleye pollock sampling by an echo sounder and a bottom trawl. Note that acoustic data are collected directly under the survey vessel, while the bottom trawl catches walleye pollock some distance behind the vessel. Diving occurs in the time between the vessel passing over the school of walleye pollock and the trawl catching the same school.

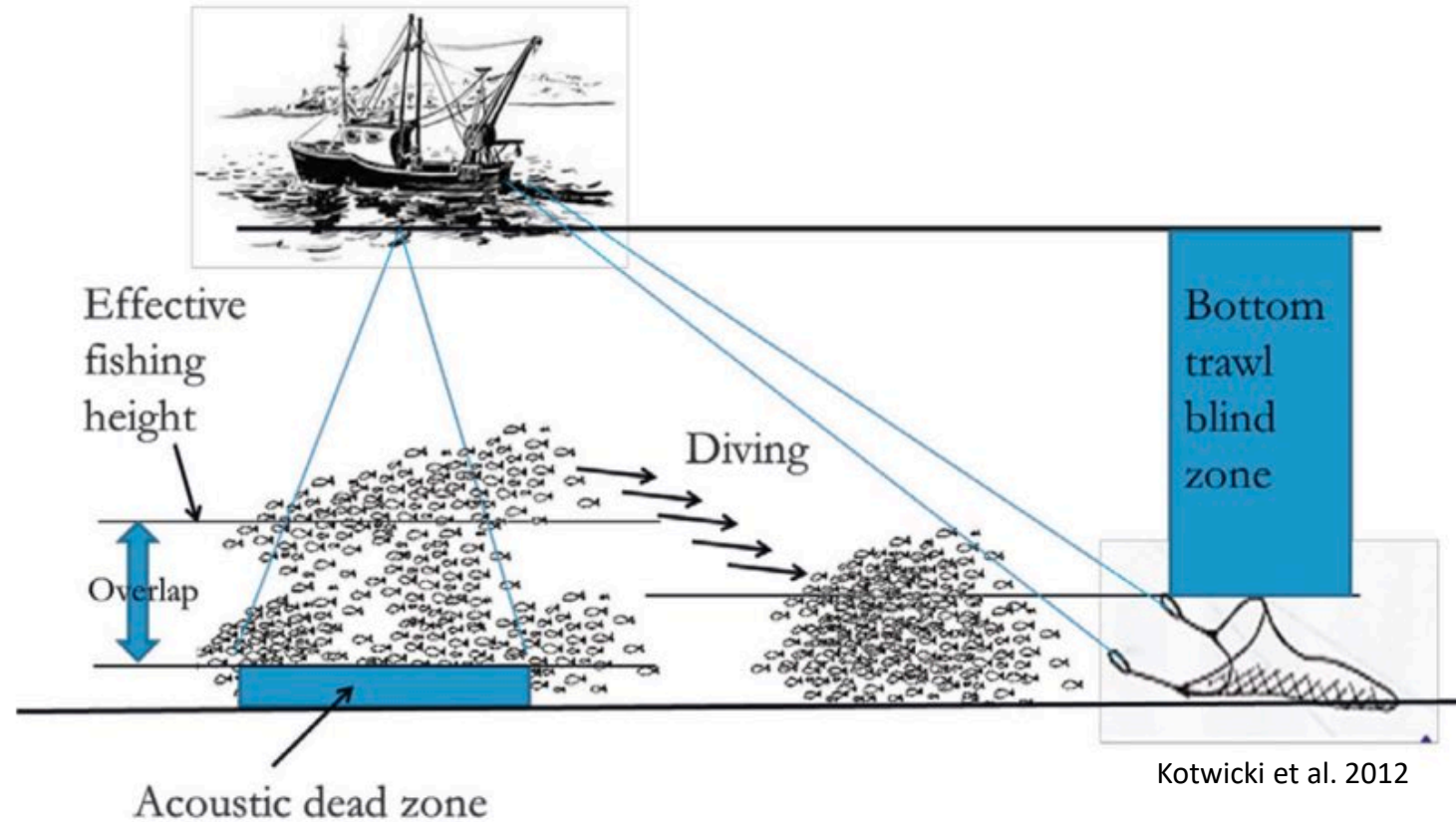

Measuring Seafloor Contact



- 2024-2025 Crab Disaster RFP:
Developing a real-time sensor to inform fishing decisions on gear position relative to the seafloor



Integration of BCS

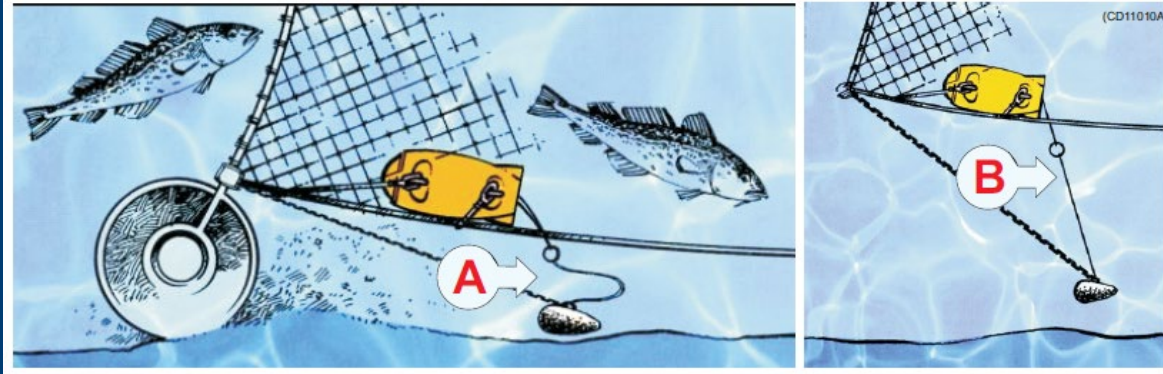

- Challenges, time/effort, to integrate a new regulatory technology (e.g., lessons learned from other programs like electronic monitoring)
 - Development of technology
 - Development of best practices
 - Data collection and processing/ turn around time
 - Who owns the data?
 - ...
- Focus on gear modification and understanding fishing parameters

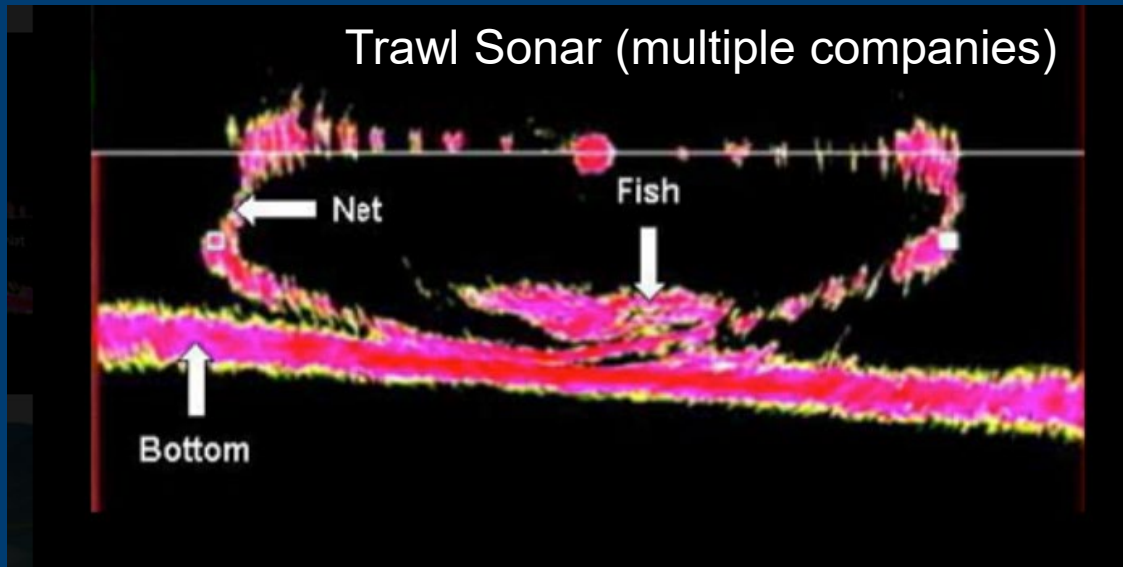

Understanding the Gear



Pelagic Trawl

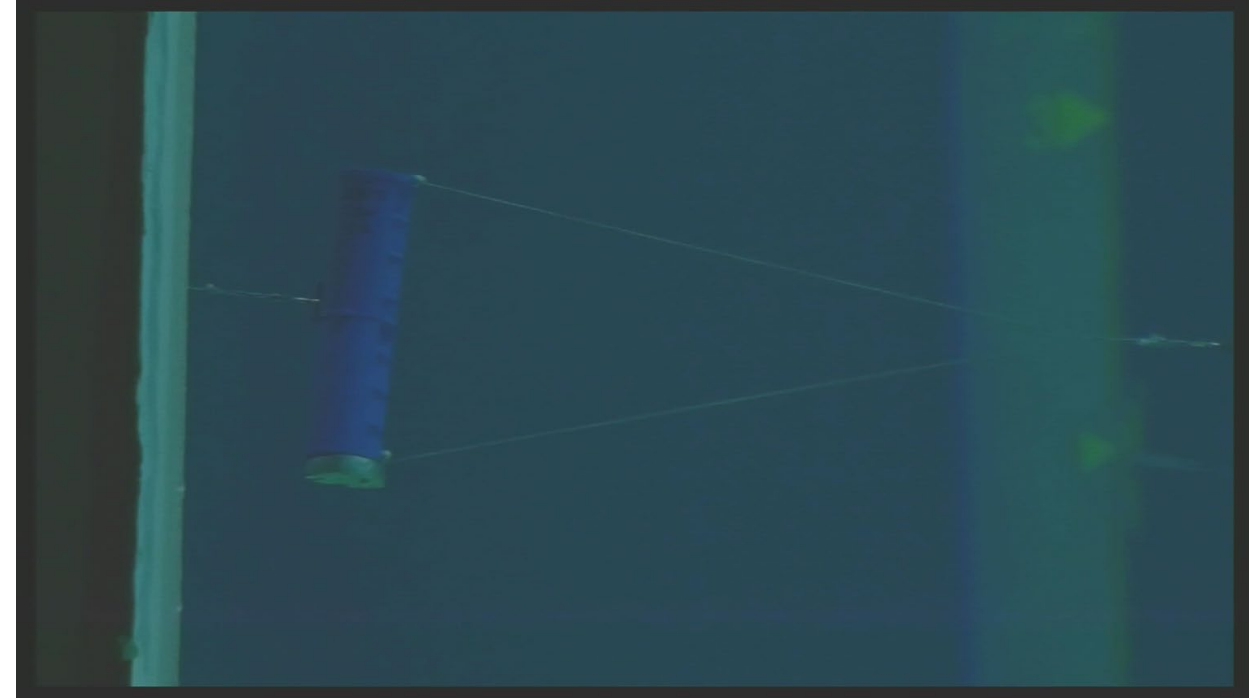
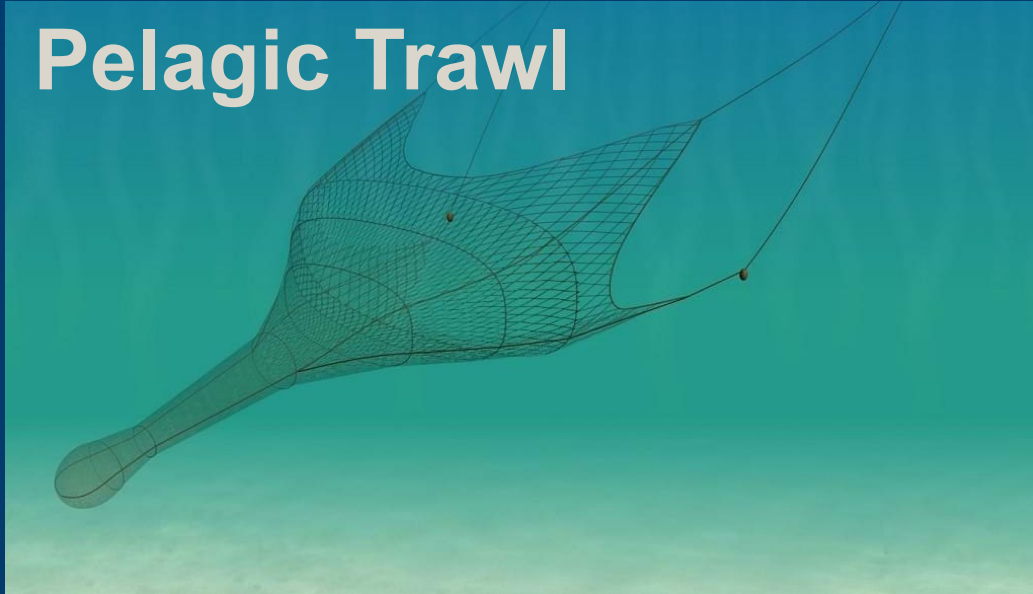

Understanding the Gear



Midwater trawls and their operation. (1971).
In *Modern Fishing Gear of the World*.

- Importance of the flexibility of the trawl to harvest animals that “inhabit various water levels” - with depth varying “widely in space and time”.
- “...fundamental first essentials for success in midwater trawling...are...the means for ensuring that the trawl operates at the required depth. Thus, whereas most ground trawling is still conducted without the use of specific fish detection devices, their use in midwater trawling is of fundamental importance and midwater trawling has developed in close association with fish detection devices, especially the echo sounder.”

Pelagic Trawl

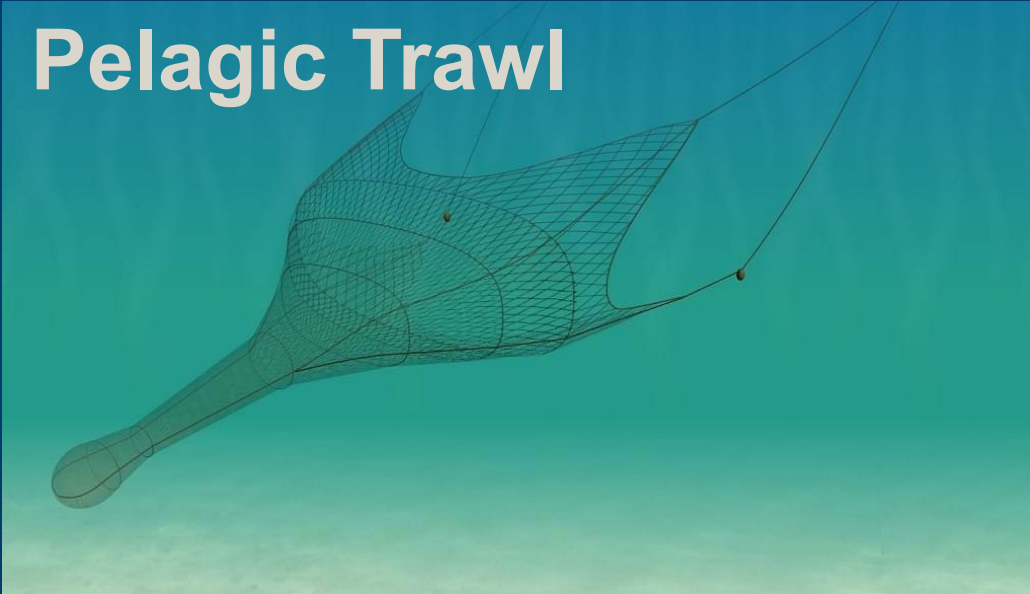

Understanding the Gear



Pelagic Trawl



- Works with an acoustic sounder for “aimed trawling” – acoustic “images” used to find the fish and target them where they are at in the water column (from near the seafloor to in shallower depths in the water column)

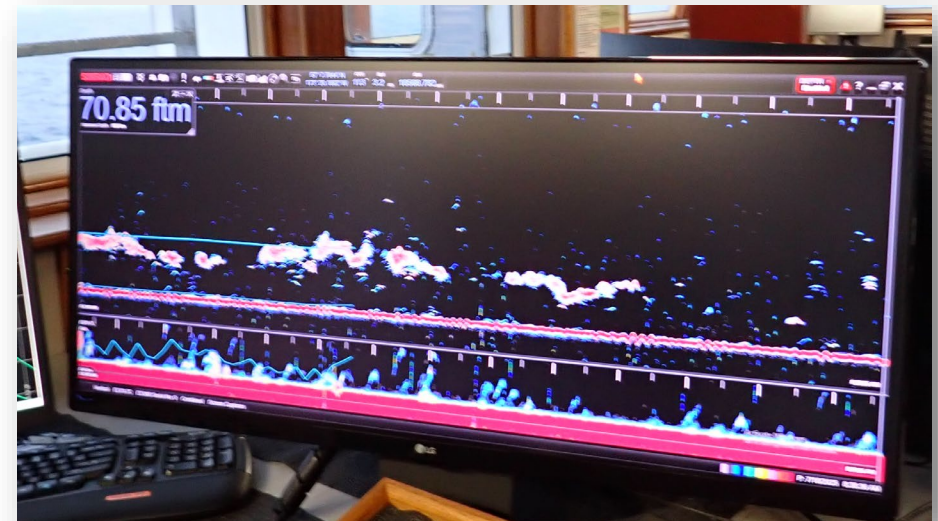

Understanding the Gear



Pelagic Trawl

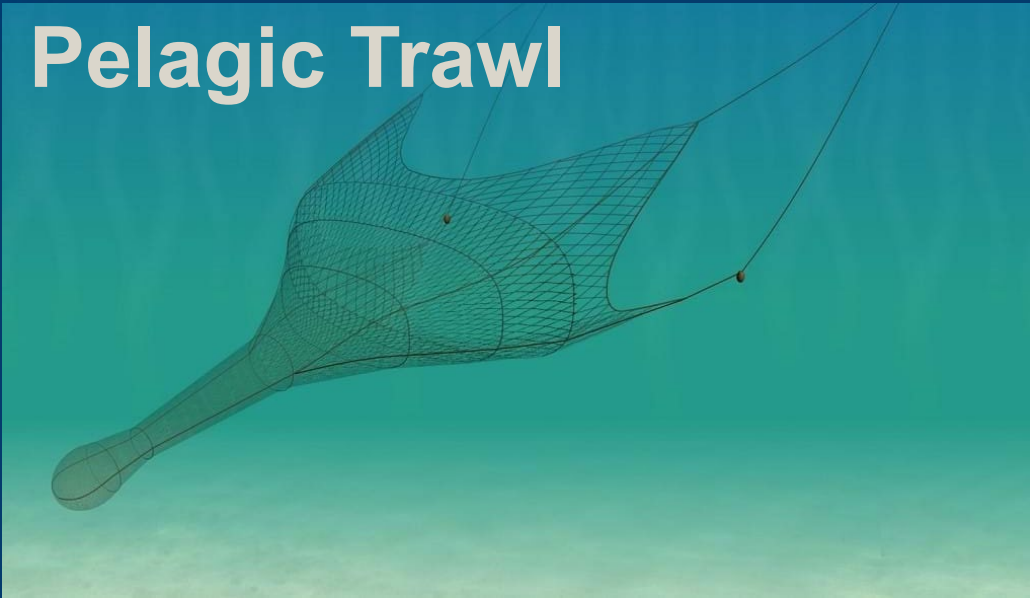

- Works with an acoustic sounder for “aimed trawling” – acoustic “images” used to find the fish and target them where they are at in the water column (from near the seafloor to shallower depths in the water column)

Bottom Trawl



- Targets animals that live on the bottom or are typically near the bottom (within capture of the vertical opening of the net); cannot move up and down in the water column

Understanding the Gear



Pelagic Trawl

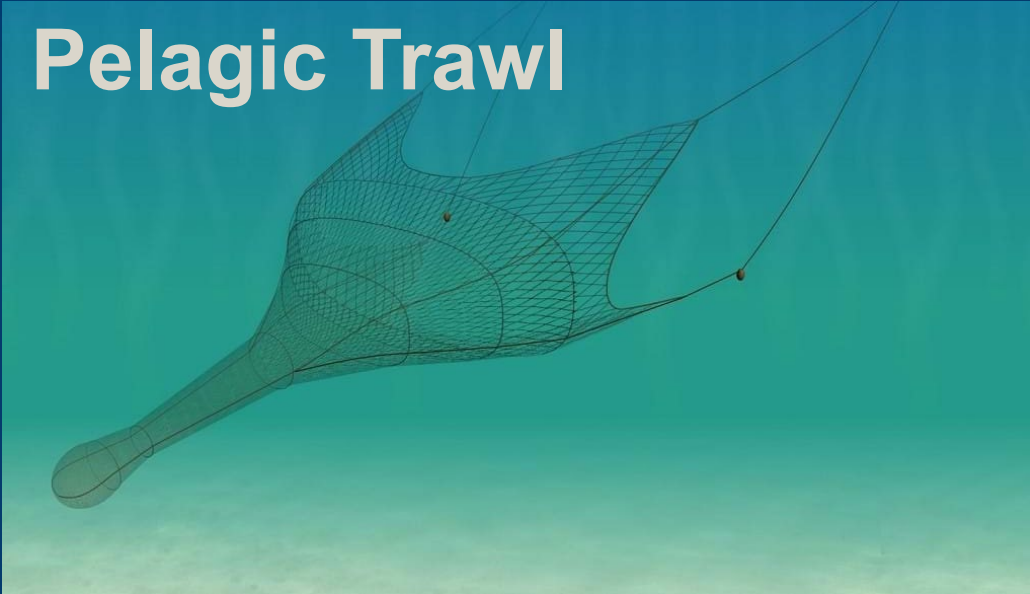

Midwater trawls and their operation. (1971).
In *Modern Fishing Gear of the World*.

- “A net with a large vertical as well as horizontal mouth openings... To achieve a large vertical opening, floats or shearing devices are attached to the headline and weights and/or depressing devices to the footrope. These features mark the most striking lines of departure in general design from the ground trawl pattern.”

Vertical Opening – “Trawl Mouth”



Pelagic Trawl

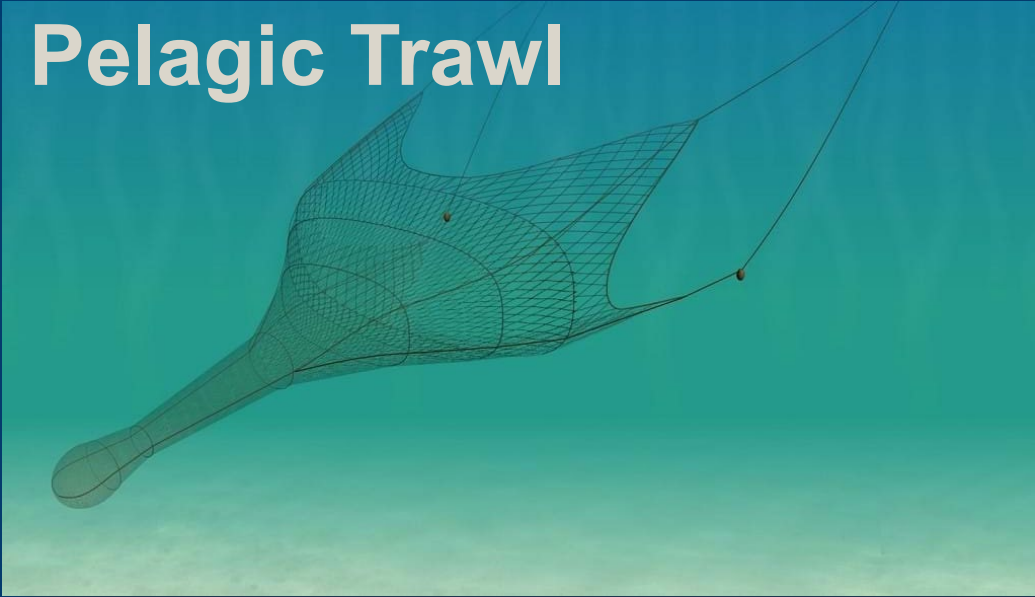

- Net suspended in the water column, using spreading forces and weight to create a large ‘mouth’ opening

No floats

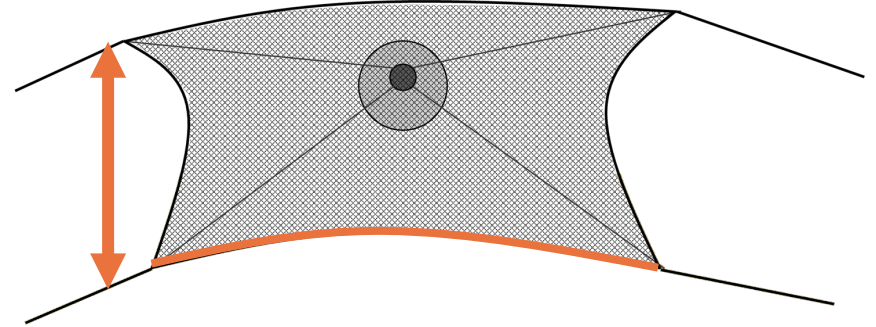

“Clump” weight

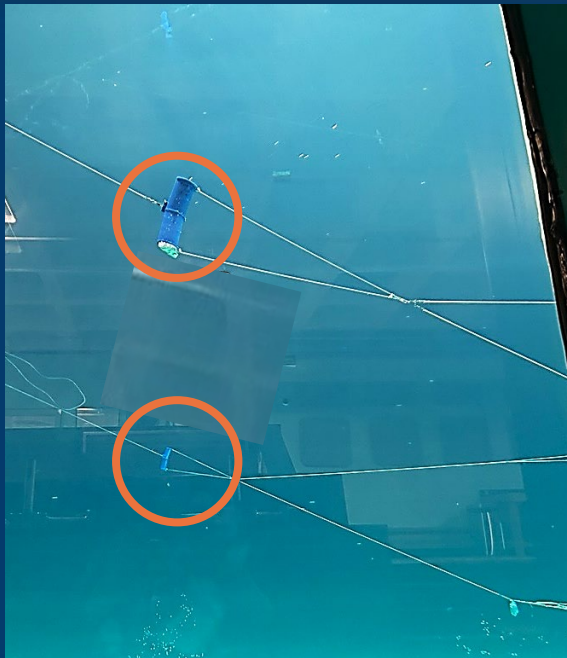

Trawl “doors”



Vertical Opening – “Trawl Mouth”

Pelagic Trawl

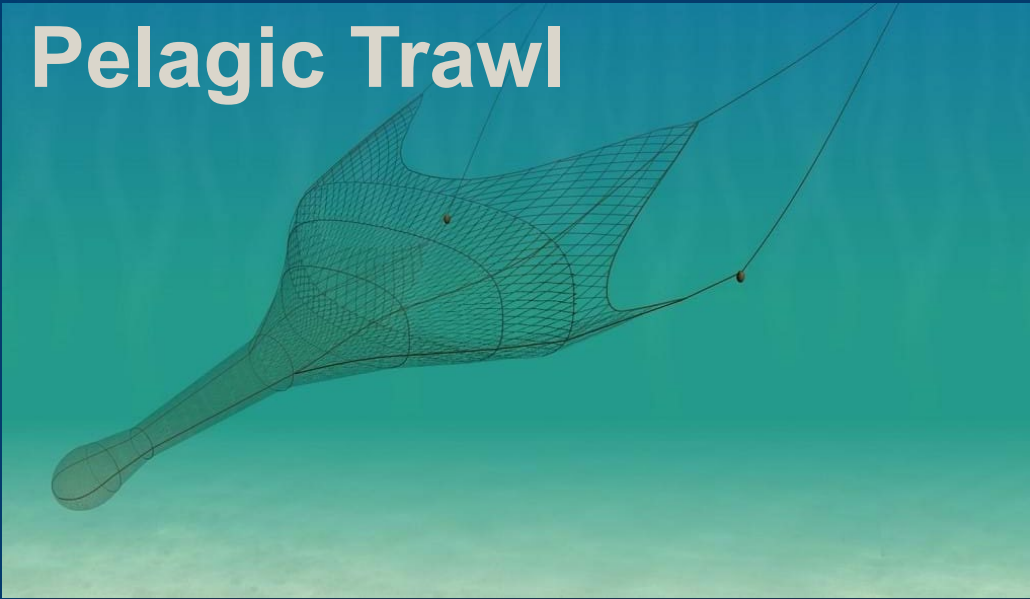

- Net suspended in the water column, using spreading forces and weight to create a large ‘mouth’ opening

No floats

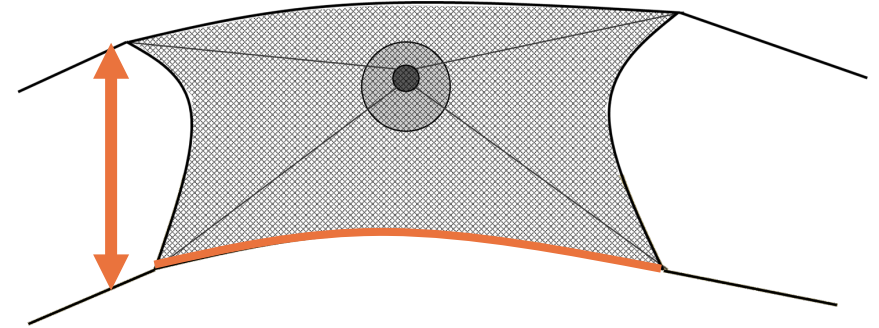

- The footrope (and clump weights) is there to provide weight to counteract the spreading forces to open the net

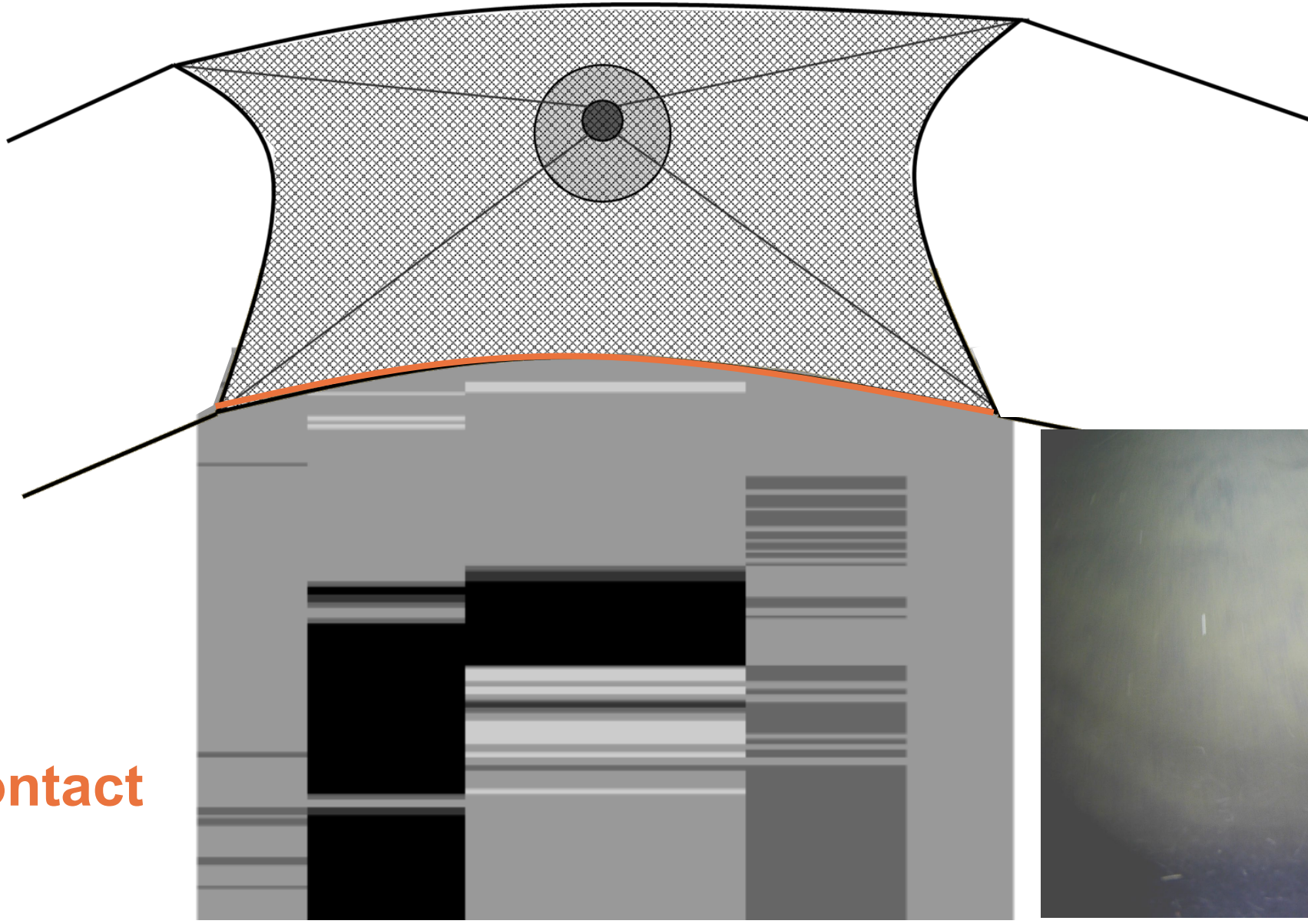

Variable Contact

Contact <5.1cm	5.1 - 10.2cm	10.2 - 15.3cm	15.3 - 20.4cm	20.4 - 25.5cm	>25.5cm
<2"	2-4"	4-6"	6-8"	8-10"	>10"

King 2019

Vertical Opening – “Trawl Mouth”



Pelagic Trawl

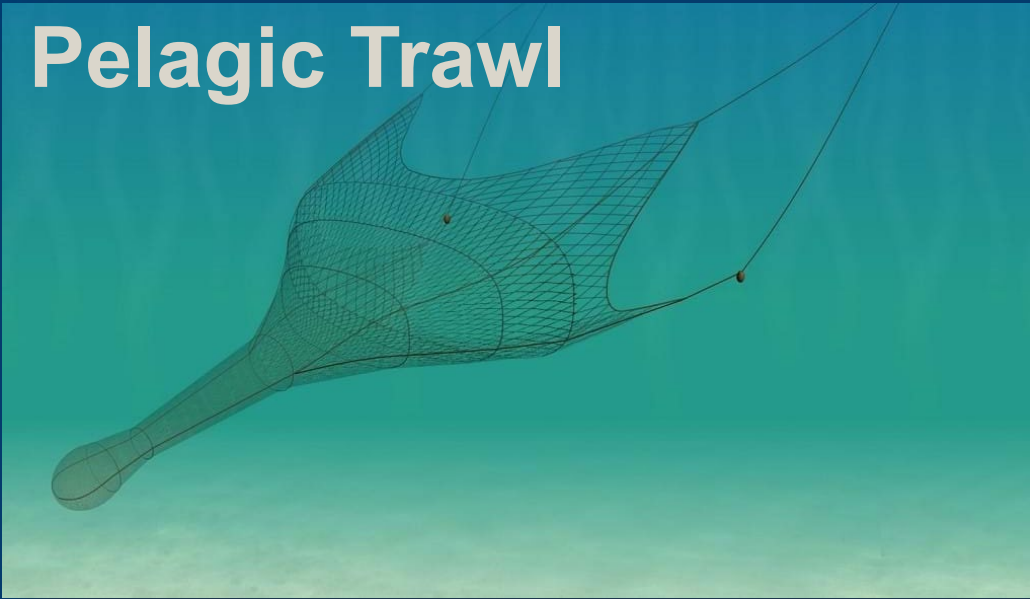

- Net suspended in the water column, using spreading forces and weight to create a large ‘mouth’ opening
- The footrope (and clump weight) is there to provide weight to counteract the spreading forces to open the net
- Doors collapse if on bottom

Bottom Trawl

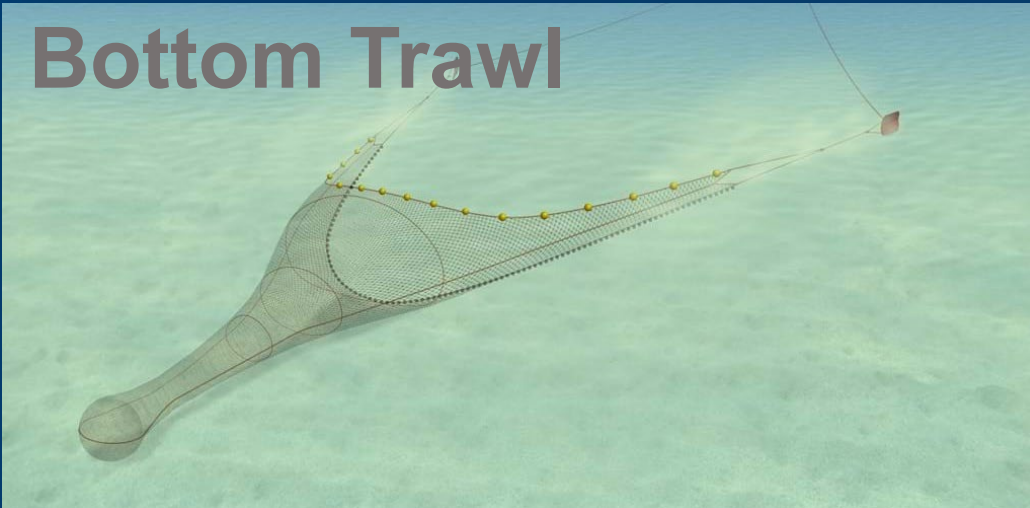

- Net opened vertically using flotation on the headline
- The footrope is designed to make uniform, consistent contact with the bottom, with attachments to traverse rocks, etc.
- Doors can be on bottom (e.g., shoes) or off

Pelagic Trawl Footrope

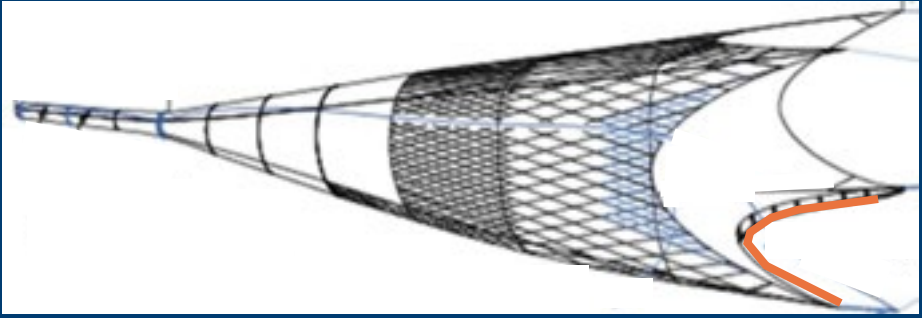

Footrope

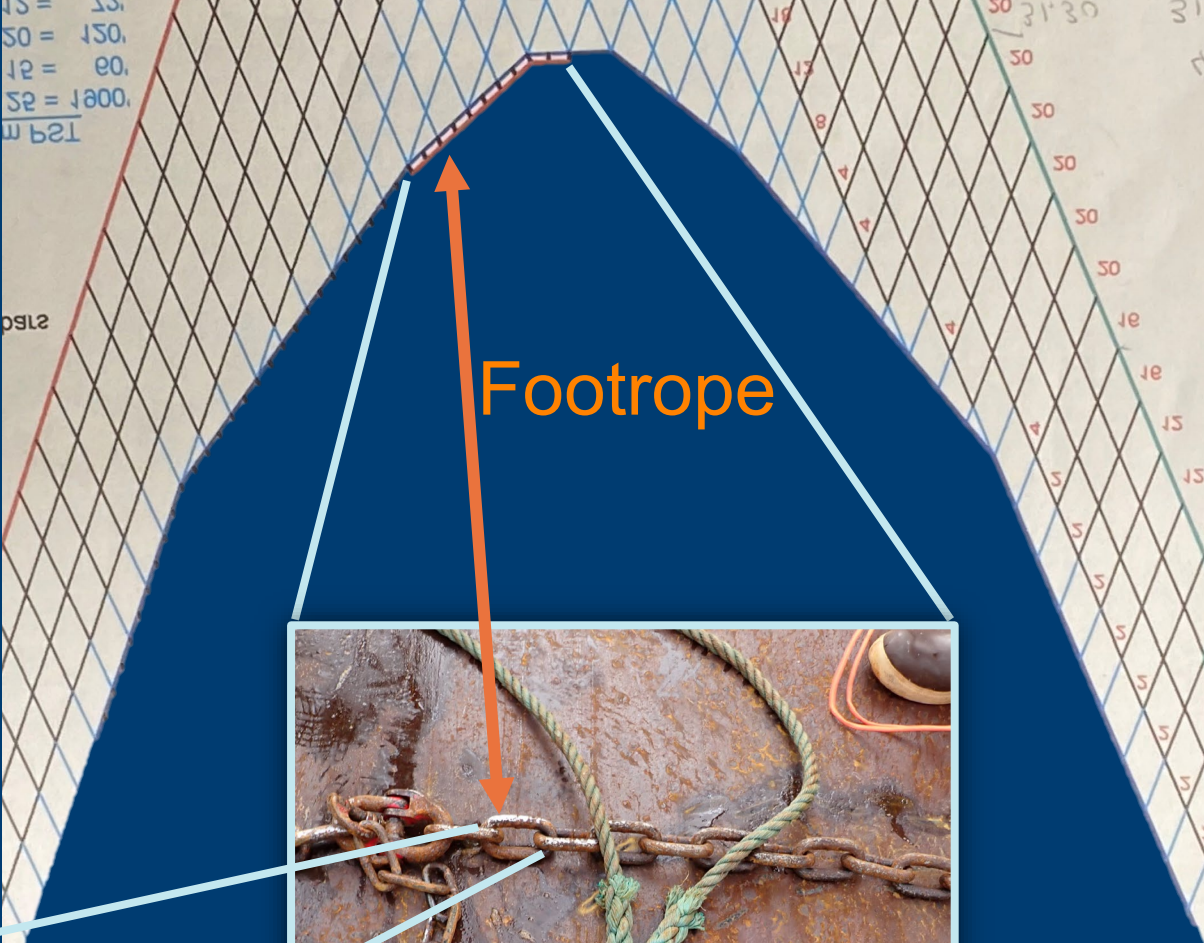

Footrope



2"



The Challenge



Pelagic Trawl

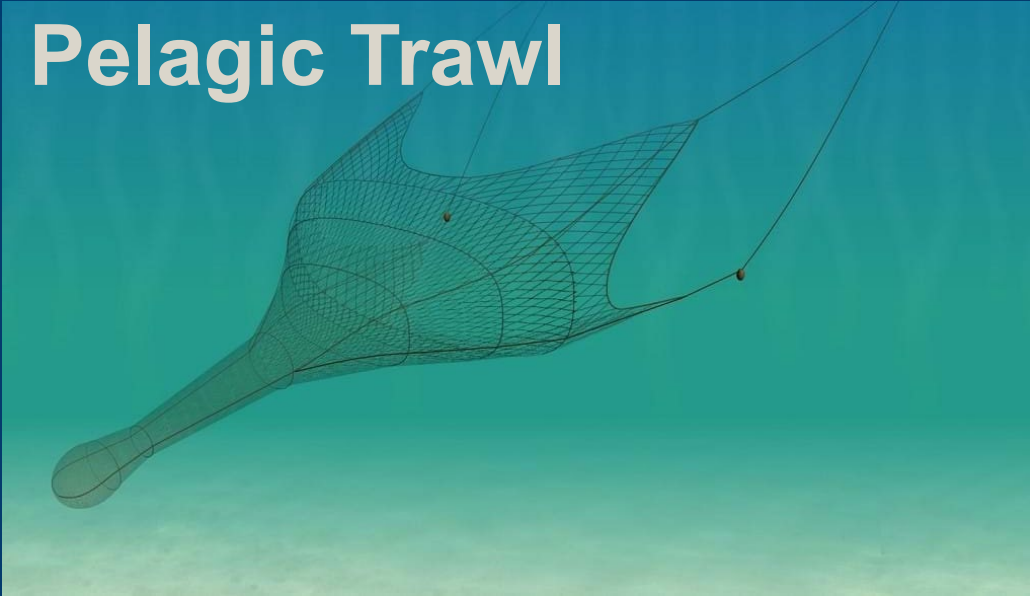

- Footrope location in the water column depends on where the pollock are found—near the seafloor or in the water column
- When fish are near the seafloor, the footrope can make contact
- Measuring contact is challenging given existing equipment and high variability in contact over the extent of the footrope and duration of the tow (King 2019)
- Uncertainty exists with respect to crab unobserved fishing mortality (UFM) and impacts to other demersal organisms

The Objective



Pelagic Trawl

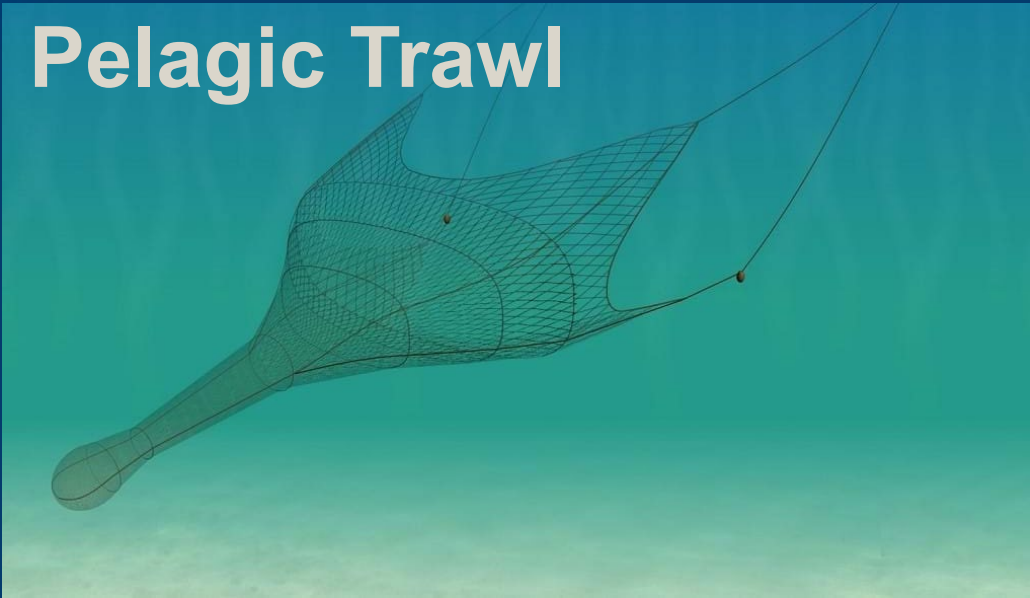

- Find an engineering solution that can overcome the presumption of UFM and negative impacts through reduced bottom contact points...
- ... while also:
 - Not impacting operations or safety
 - Being applicable to most nets used in the CV/CP fleets
 - Being affordable
 - Not requiring major modifications or change to repair/replacement schedule
 - Not increasing bycatch (e.g., salmon)
 - Not reducing efficiency (i.e., pollock catch)

Fishing Efficiently Means Less Impact

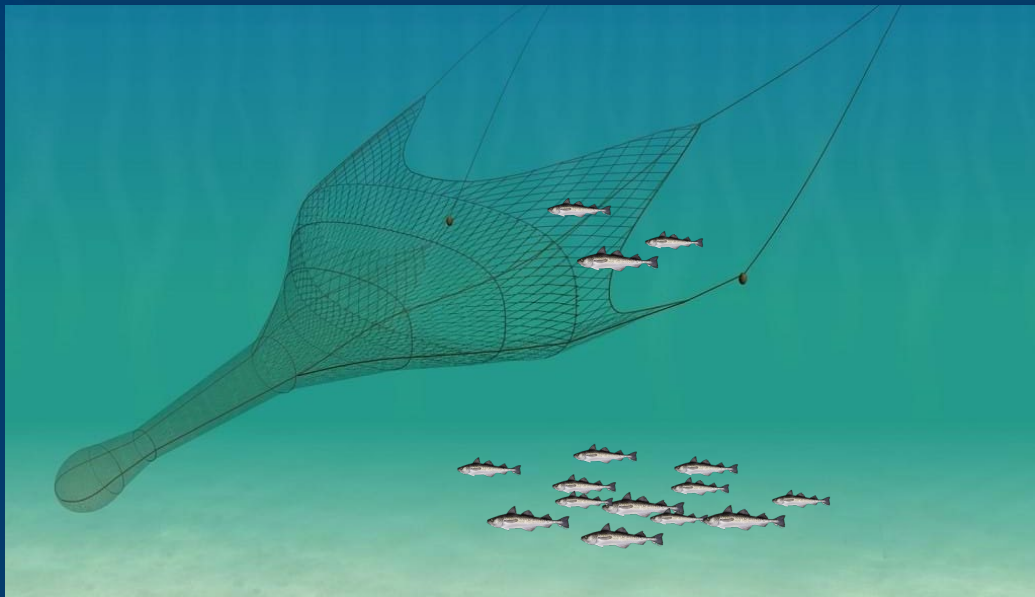
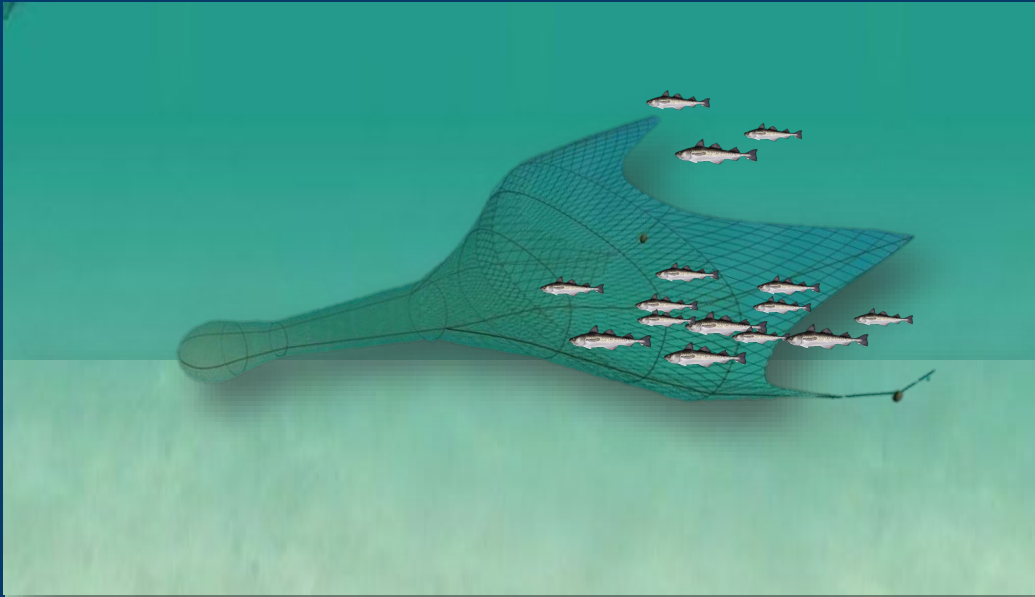

Fishing Off-Bottom (when the fish are there) is **Not an Effective Solution** to Minimizing Impacts

Fishing Efficiently Means Less Impact

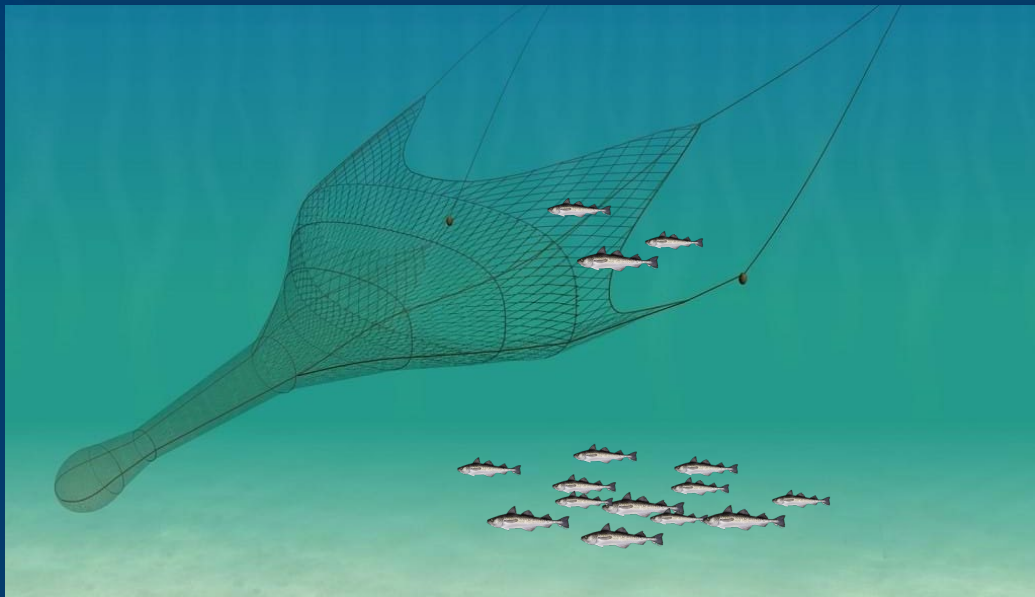
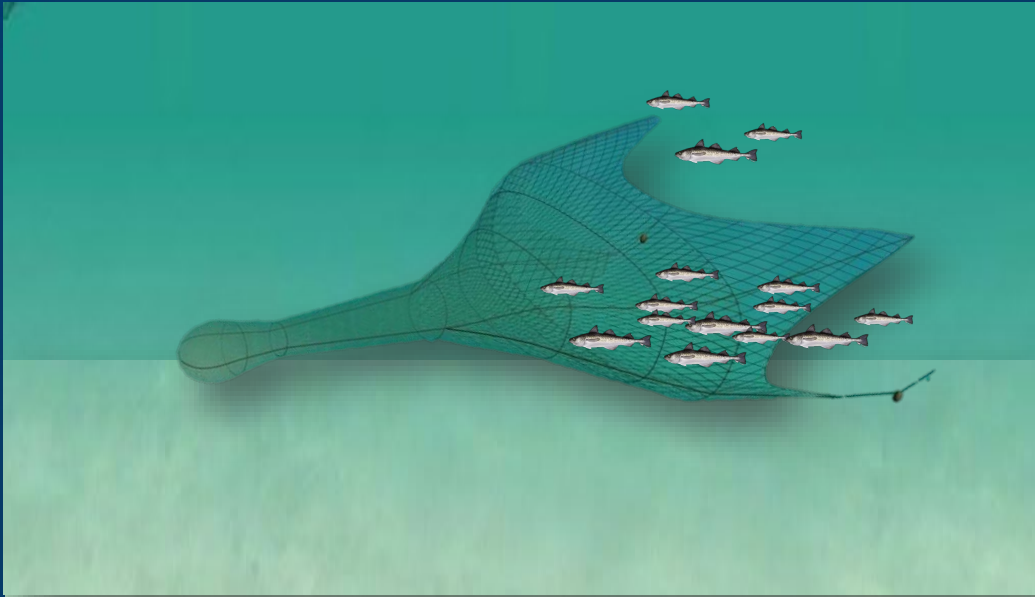

Fishing Off-Bottom (when the fish are there) is **Not an Effective Solution to Minimizing Impacts**



- Non-targeted fishing means increasing the number of tows to get the same amount of quota
- This results in:
 - Increased time the gear is in the water (potential bottom contact, fuel use, etc.)
 - Increased opportunities to encounter bycatch animals/ Prohibited Species Catch (PSC)
 - Increased time on the water and therefore more opportunities for safety issues for the crew

Fishing Efficiently Means Less Impact

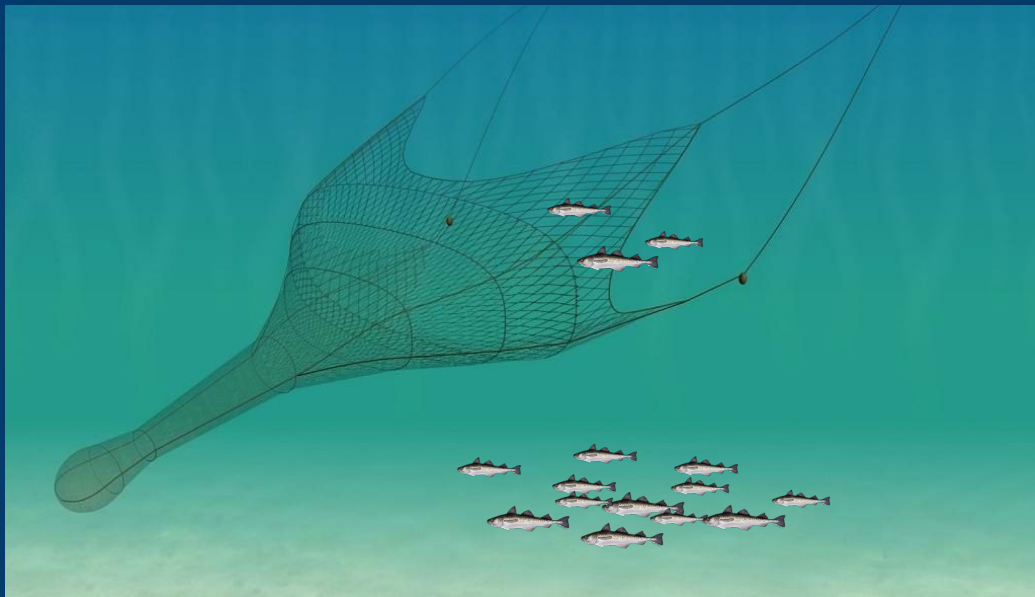
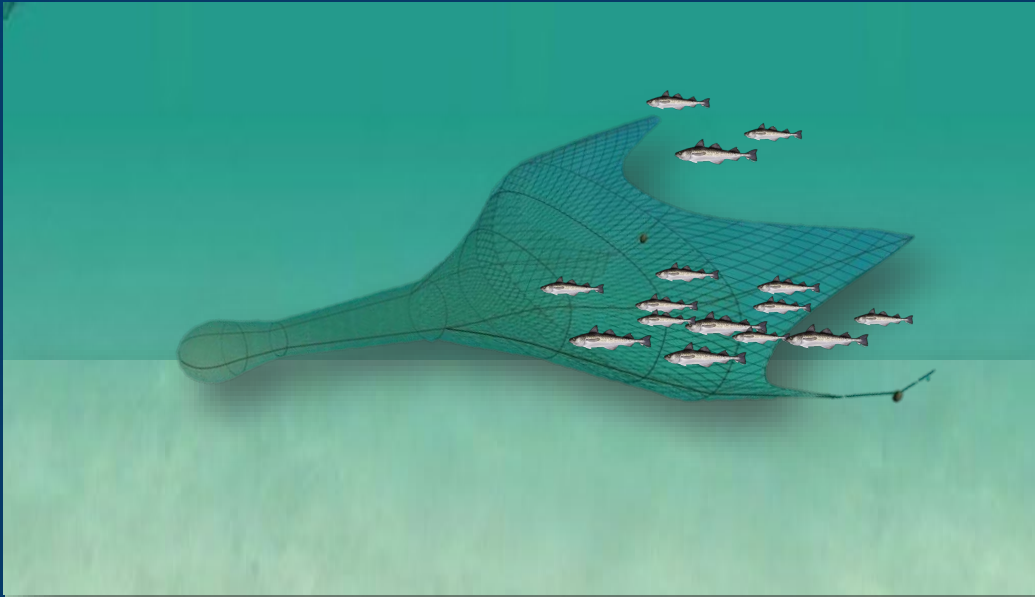

- **Quota: 100 Units**
- **1 Tow: 2 Units of Fuel**
- **1 Tow: 5 Units of Bycatch**

- **Efficient Tows: 10 Quota Units/ Tow**
 - 10 Tows Needed (to get 100 quota units)
 - 20 Units of Fuel
 - 50 Units of Bycatch
- **INEfficient Tows: 5 Quota Units/ Tow**
 - 20 Tows Needed **50% reduced contact**
 - 40 Units of Fuel
 - 100 Units of Bycatch

0% reduction in contact for the quota
Increase in fuel and bycatch

Modifying the Pelagic Trawl Footrope



Footrope

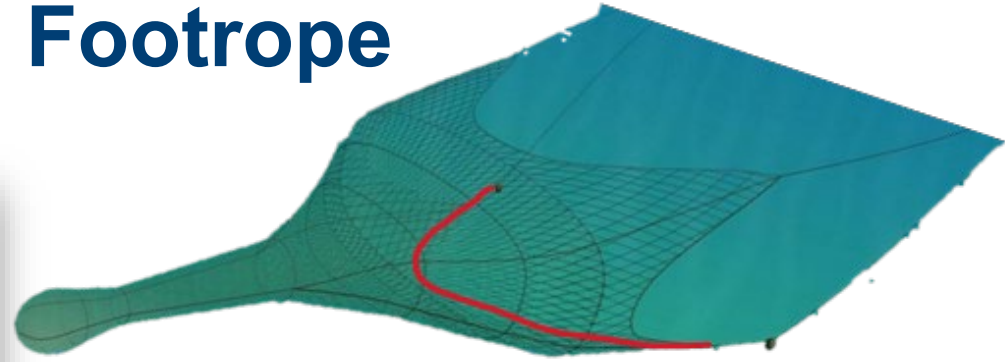

2"



A Standard Footrope Design

Looking into the Trawl Mouth

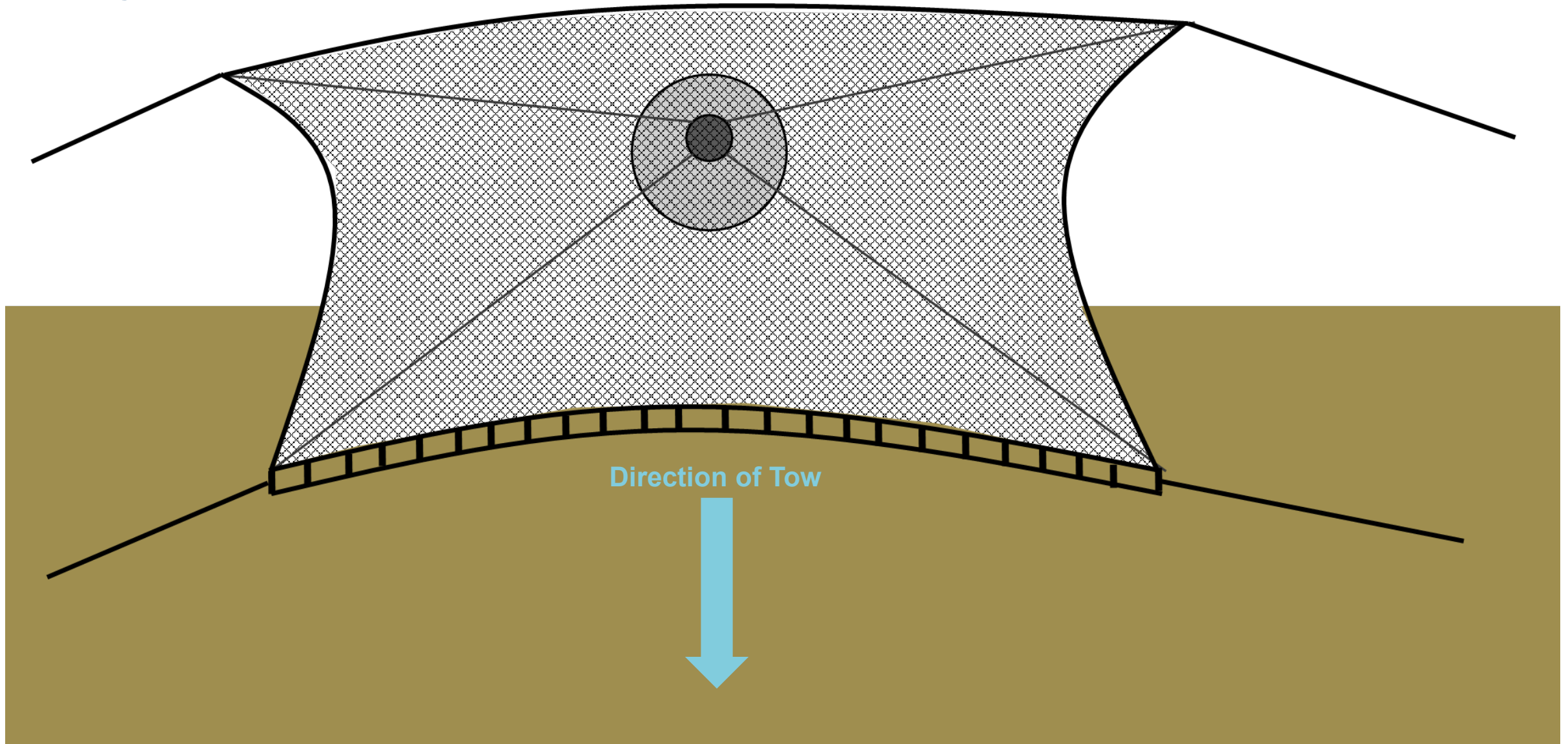

One current footrope design (not to scale)

Original Design Concept

Seamus Melly (Swan Net USA)

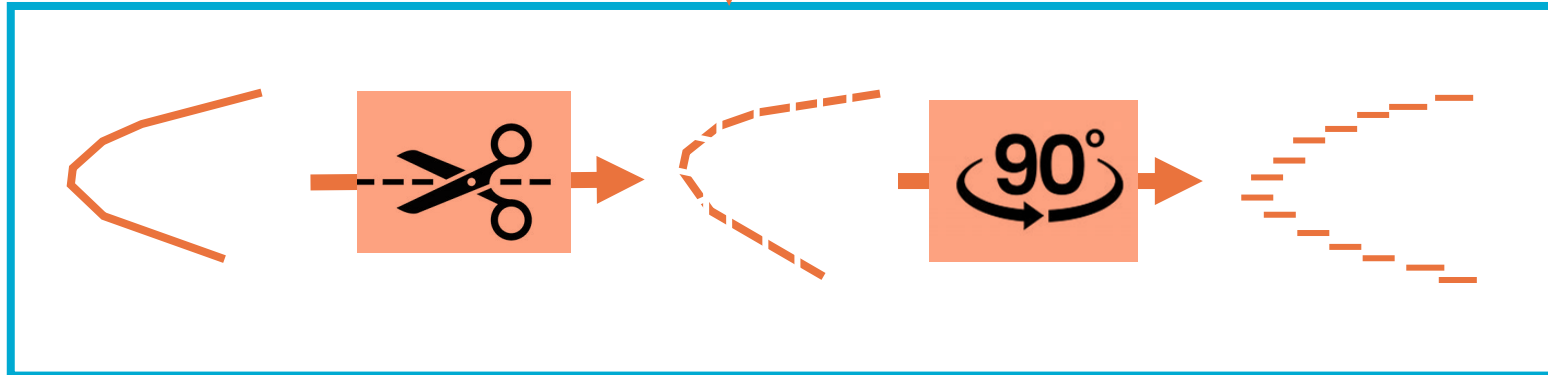
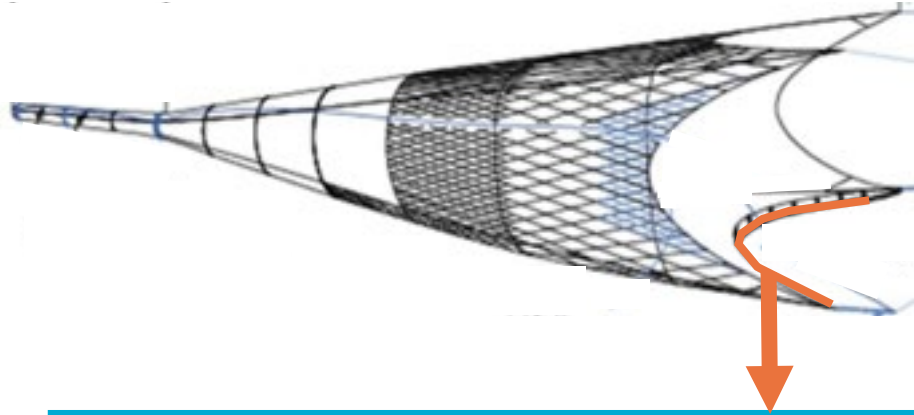

Modified Footrope Design Concept

Looking into the Trawl Mouth

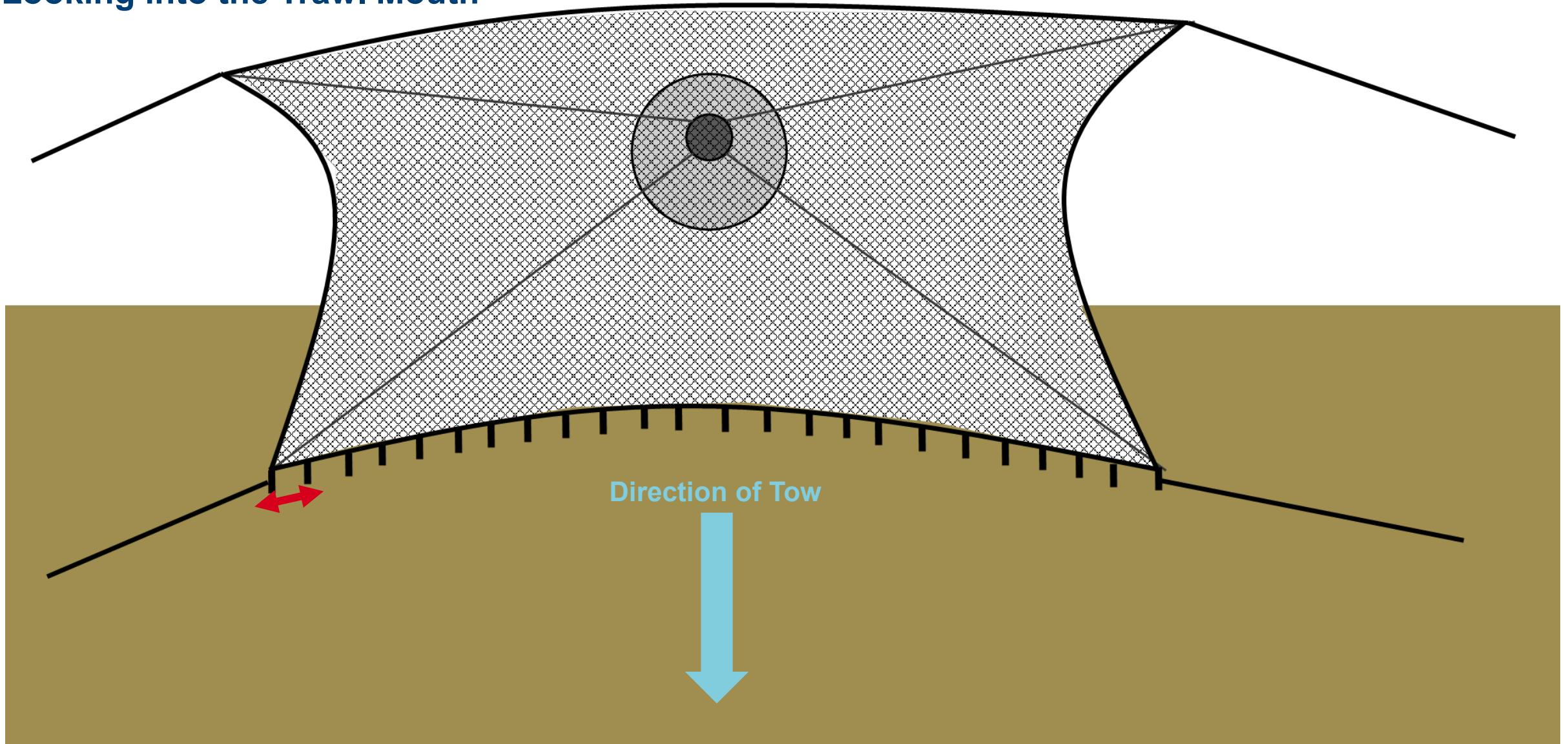

S.P.F. (not to scale)

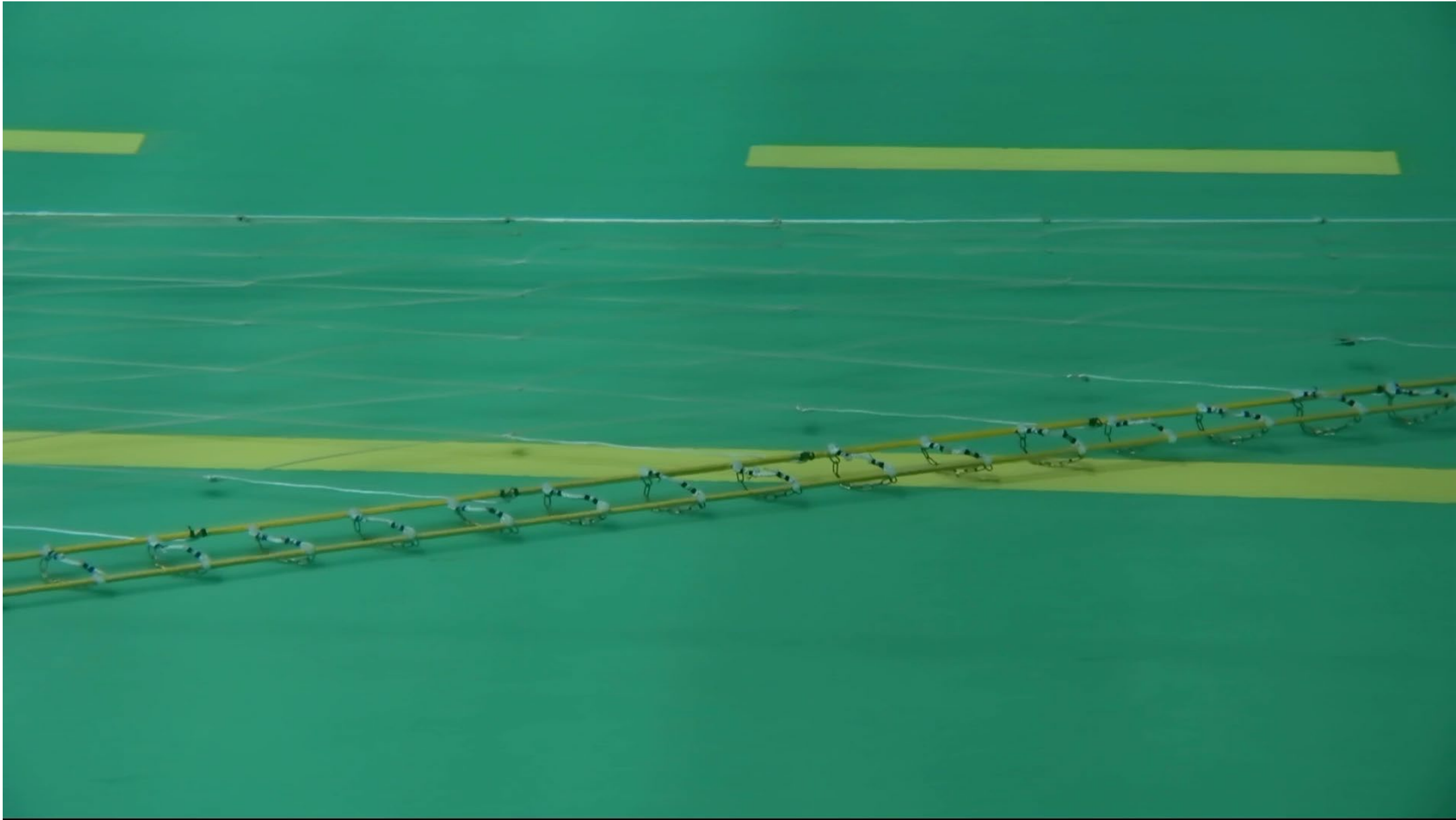

Demonstration purposes only – assumes full contact

Current Footrope Design

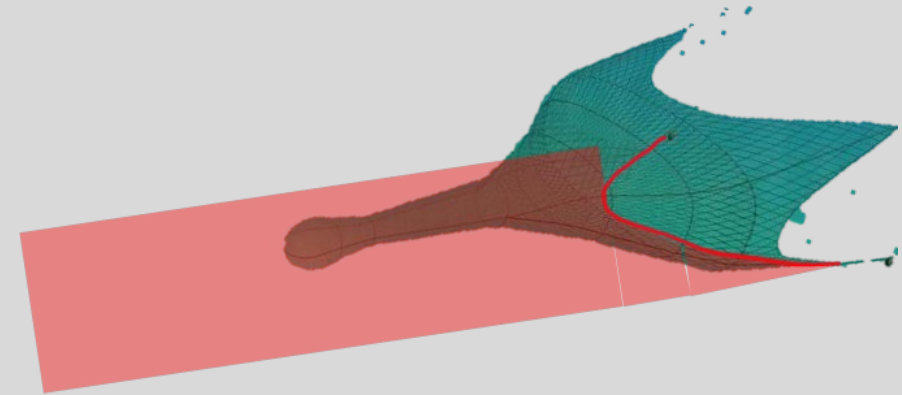
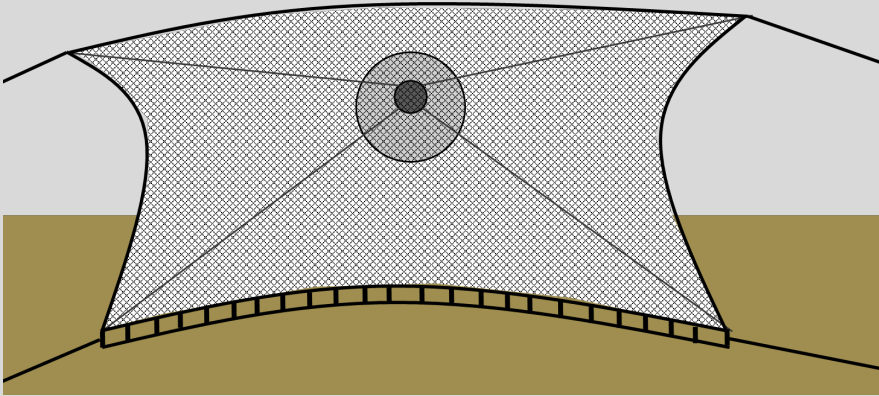

Not to scale

Assuming consistent contact over footrope for demonstration purposes only

S.P.F. (Suspended Parallel Footrope) Design

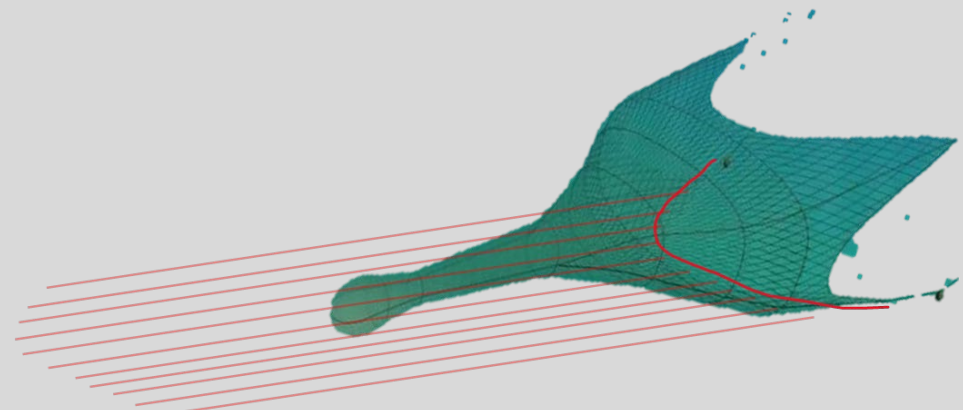
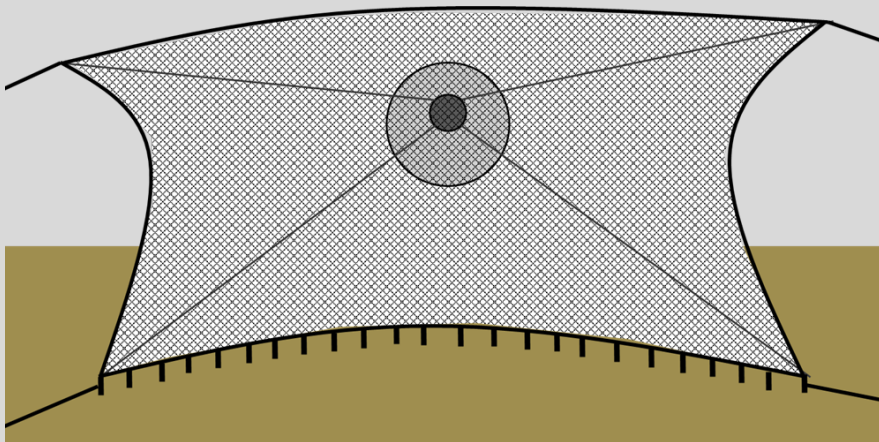

Not to scale

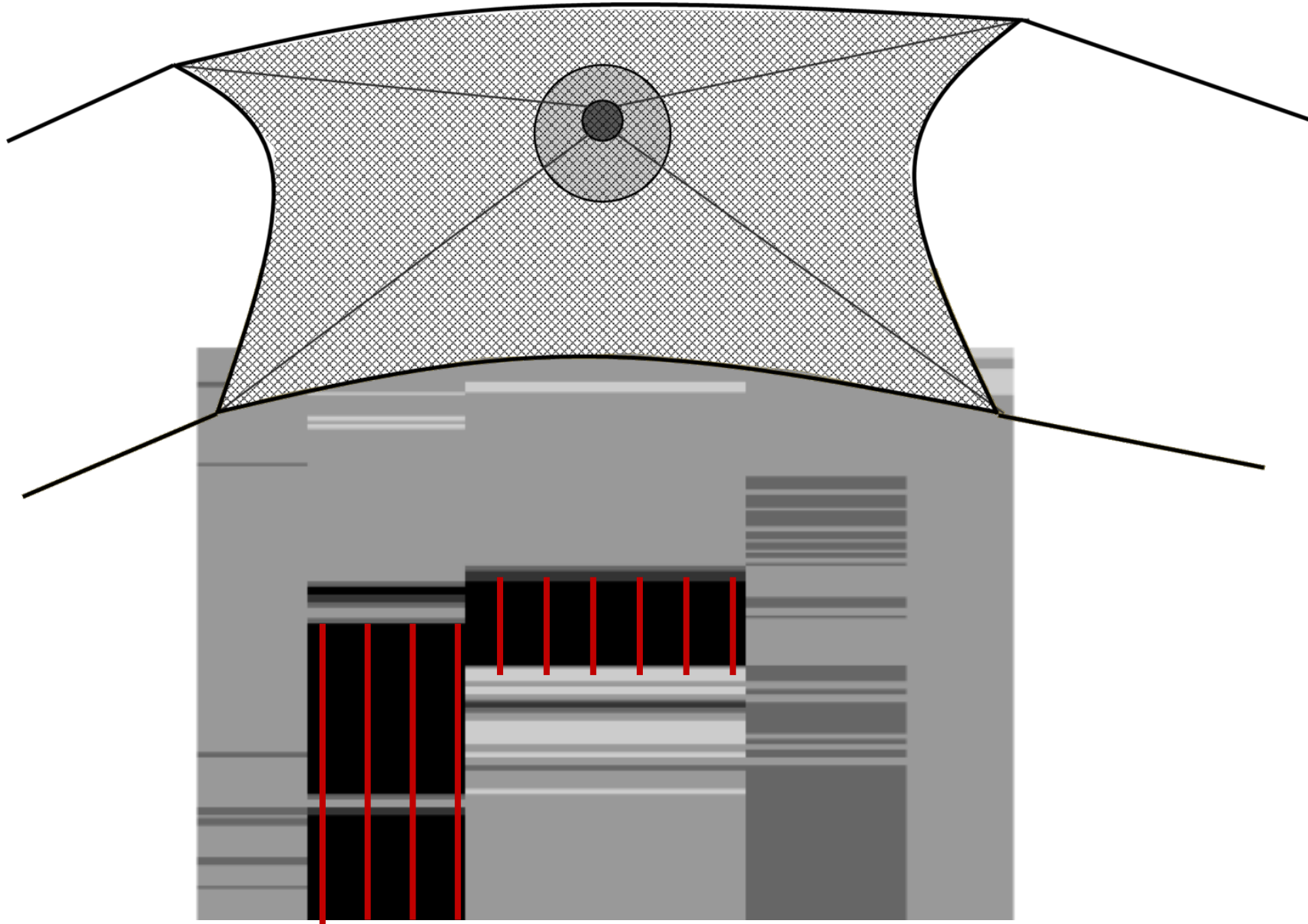

Approximated Reduction in Contact



Current footrope design

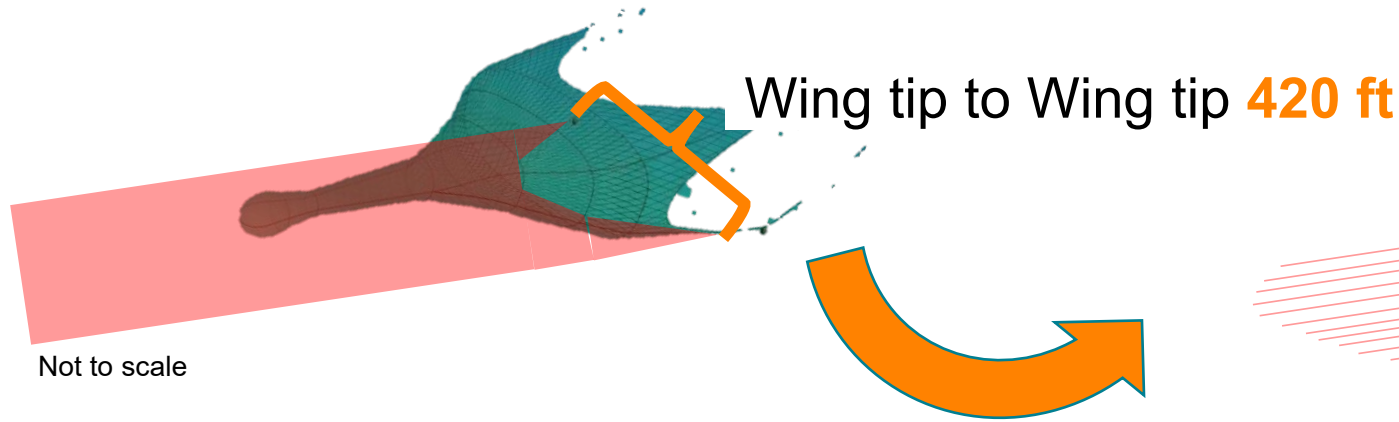

S.P.F. design

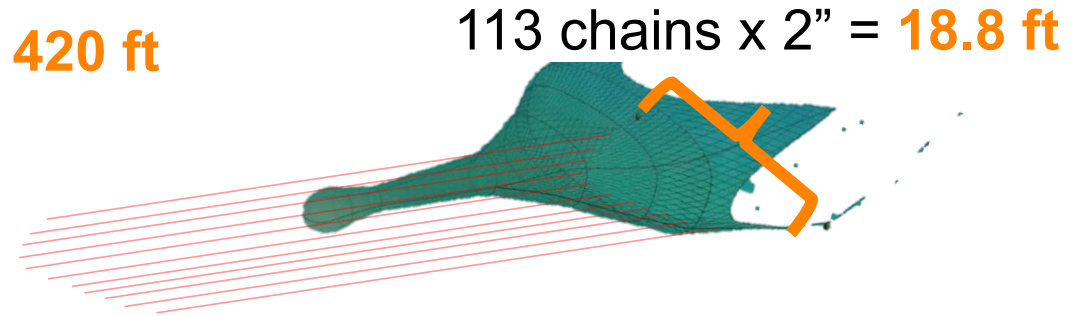

- **$420 - 18.8 = 401.2$ ft less contact ***
- **$401.2 / 420 = 96\%$ reduction in contact ***

* Assuming even contact over footrope and the duration of tow
(overestimating contact based on King 2019 and observations from this study)



S.P.F. Development Timeline

- **2023A:** Tested/developed camera system; finalized footrope design concept/ net plan (Swan Net)
- **2023B:** Tested the SPF on a Trident CV
 - Changes to operations, safety, efficiency (captain and crew feedback)
 - Catch composition
 - Research data collection

Cameras



Monitored for:

- Angle of contact with the chains (parallel with direction of tow)
- Contact/ clearance of fishing lines
- Interactions/ fish behaviour
- Variables that affect variability
- Gear performance/ any tangling

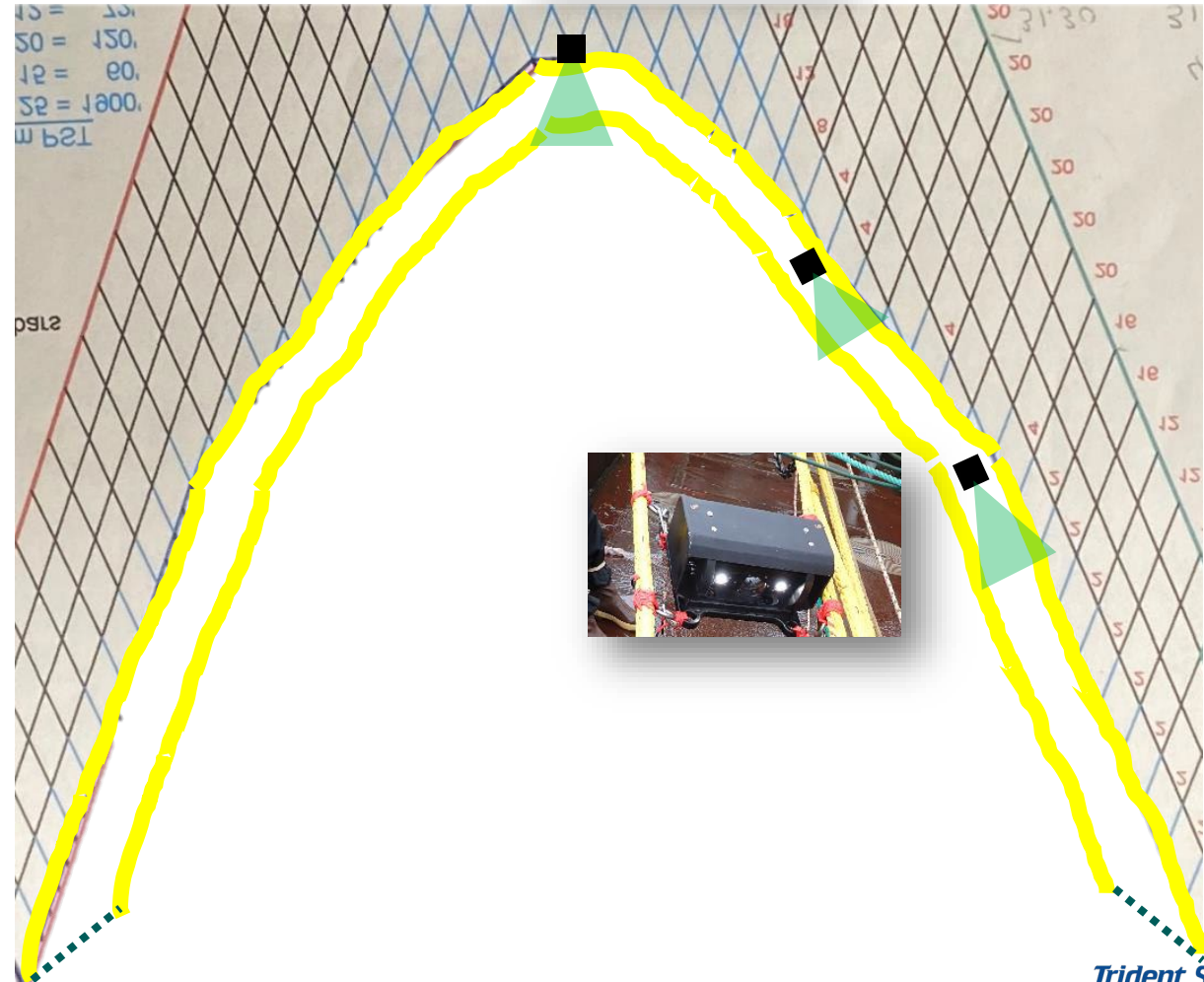
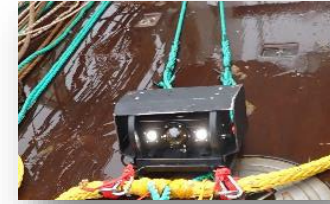

Sensor Data: Temperature and Depth

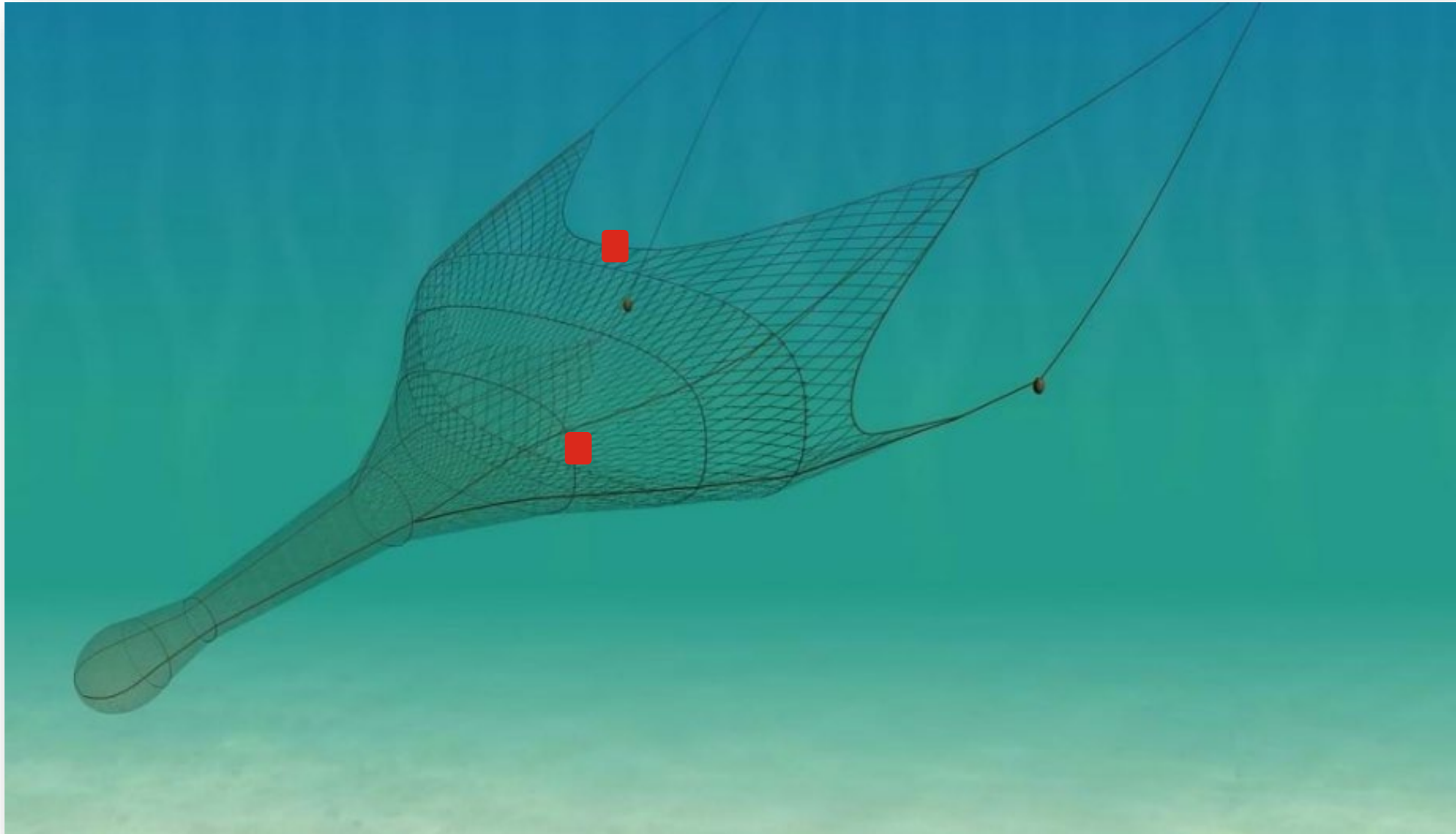

Chain/ Rope Inspection

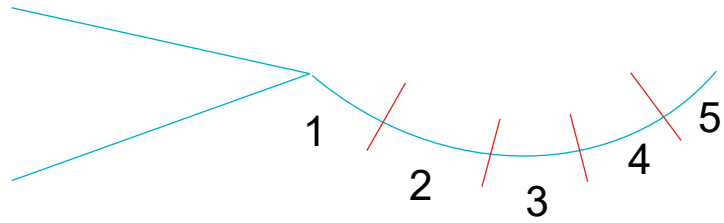

- Looked for any signs that fishing lines are on bottom
- Looked at location of shine: along bottom indicates chain parallel with tow; shine location informs distance above bottom





S.P.F. Development Timeline

- **2023A:** Tested/developed camera system; finalized footrope design concept/ net plan (Swan Net)
- **2023B:** Tested the SPF on a Trident CV (research data; captain feedback and catch data)
- **2024A:** Tested the SPF on 2 Trident CVs (captain feedback and catch data)
- **2024B:** Tested the SPF on 4 Trident CVS (captain feedback and catch data) and on a Trident CP (research data; captain feedback and catch data)
- **2025A [EFP 25A – 27B]:** Tested the SPF on 4 Trident CVs and 1 Trident CP (captain feedback and catch data)
- **2025B:** Tested the SPF v2.0 on a Trident CP (research data); and v1.0 on 4 Trident CVs and v2.0 on 1 Trident CP (captain feedback and catch data)

S.P.F. v2.0



- After the center and until the wingtips (last 8 bars), removed every 3rd chain (21% reduction in weight)

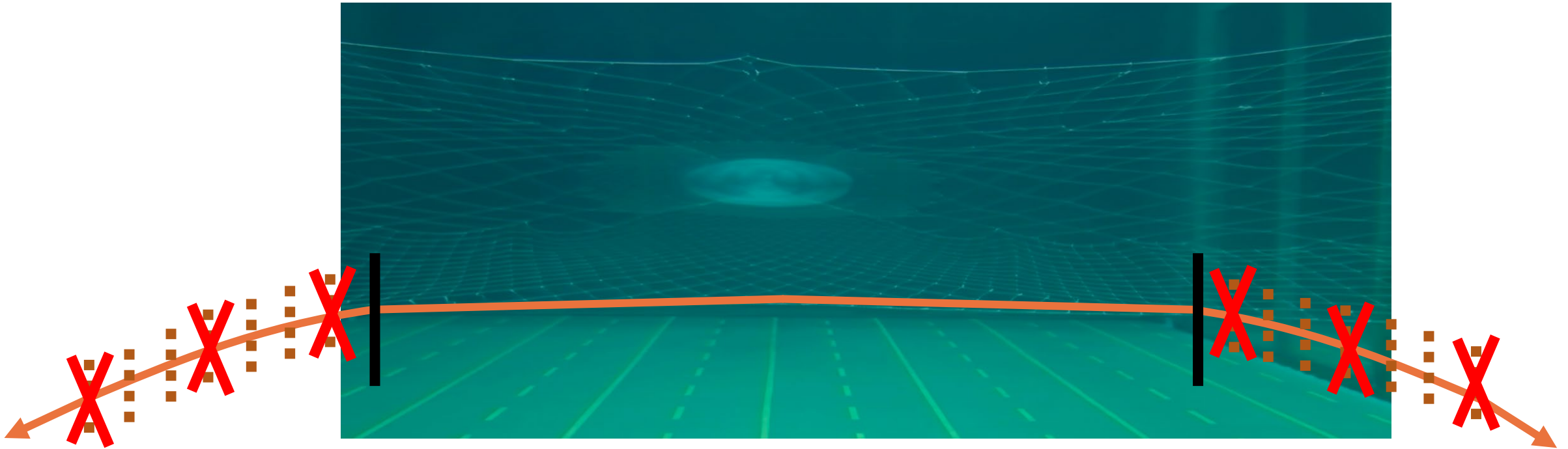



S.P.F. Development Timeline

- **2023A:** Tested/developed camera system; finalized footrope design concept/ net plan (Swan Net)
- **2023B:** Tested the SPF on a Trident CV (research data; captain feedback and catch data)
- **2024A:** Tested the SPF on 2 Trident CVs (captain feedback and catch data)
- **2024B:** Tested the SPF on 4 Trident CVS (captain feedback and catch data) and on a Trident CP (research data; captain feedback and catch data)
- **2025A [EFP 25A – 27B]:** Tested the SPF on 4 Trident CVs and 1 Trident CP (captain feedback and catch data)
- **2025B:** Tested the SPF v2.0 on a Trident CP (research data); and v1.0 on 4 Trident CVs and v2.0 on 1 Trident CP (captain feedback and catch data)
- **2026A:** SPF provided to all Trident BS pollock vessels (6 CVs, 2CPs); 2 CVs will start use 2026B
- **2026B:** SPF used on all Trident BS pollock vessels



S.P.F. Development Timeline

Vessels and Nets

- Vessel length (ft): 111-274
- Vessel HP: 1525-6638
- Different net designs: 6
- Longest consistent use: Since 2023B



S.P.F. Development Timeline

- **Other**
 - Monitored wear over time and repaired/ replaced rope as needed
 - Modifications to CP design
 - Rope size varied by vessel HP/size
 - For CP design, reduced the number of chains in the mid-span of the wings; added “break away” features
 - Meeting with other companies
 - Working on publication with Seamus Melly
 - Trip to the flume tank



Next Steps- Data Analysis

Vessel Data - Efficiency

- Captain data collected and DFL/ catch data
- Evaluate drivers of efficiency –footrope and other

Videos- Contact

- Percentage of time the footrope is on bottom (and time when the sediment cloud prevents observation-contact/clearance is unknown)
 - Compare by location on the footrope and CV vs CP1 vs CP2
- Estimate of clearance when possible

Variability in contact – completely off bottom (different distances), barely gliding along the bottom, down enough to generate a sediment cloud

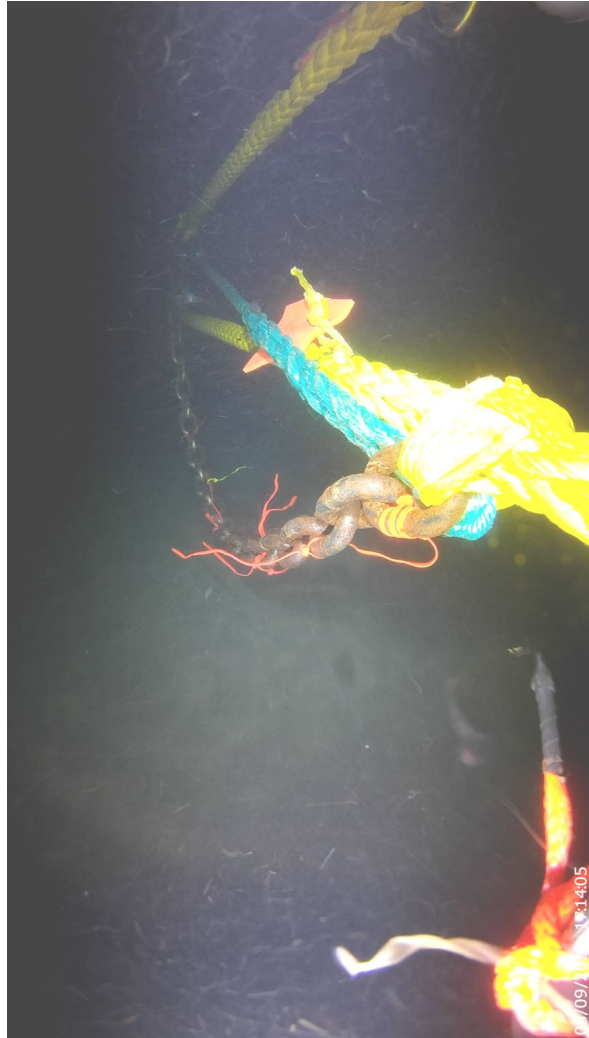



Next Steps- Data Analysis

Vessel Data - Efficiency

- Captain data collected and DFL/ catch data
- Evaluate drivers of efficiency –footrope and other

Videos- Contact

- Percentage of time the footrope is on bottom (and time when the sediment cloud prevents observation-contact/clearance is unknown)
 - Compare by location on the footrope and CV vs CP1 vs CP2
- Estimate of clearance when possible

Flume - Performance

- Variables that affect contact
- Look to see if the design is achieving the objectives



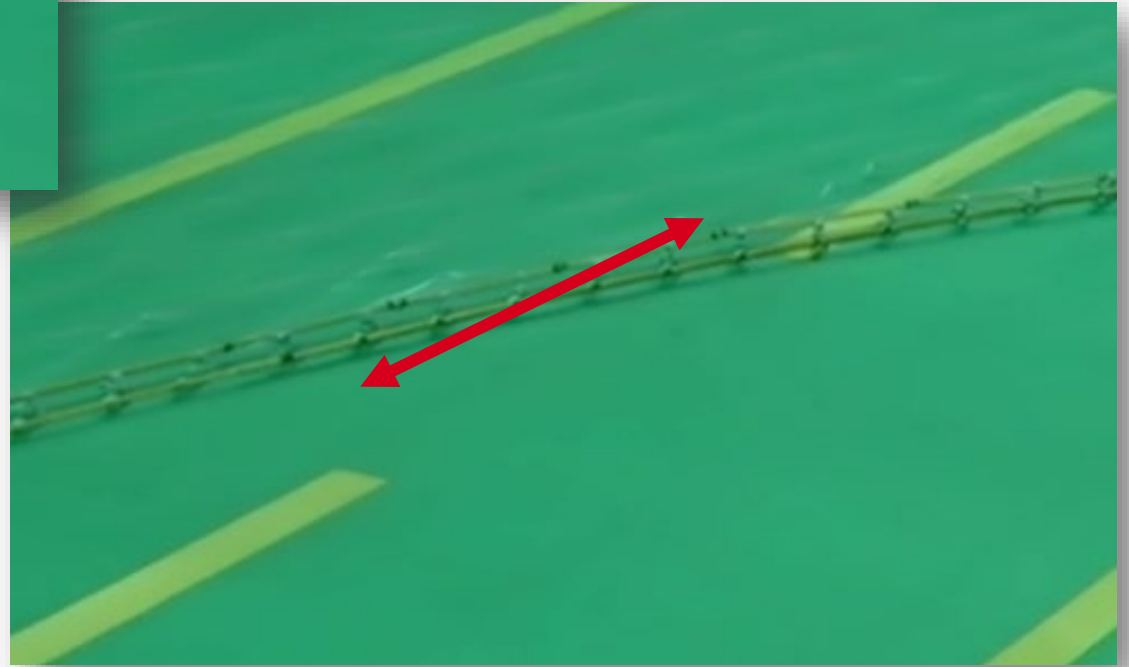
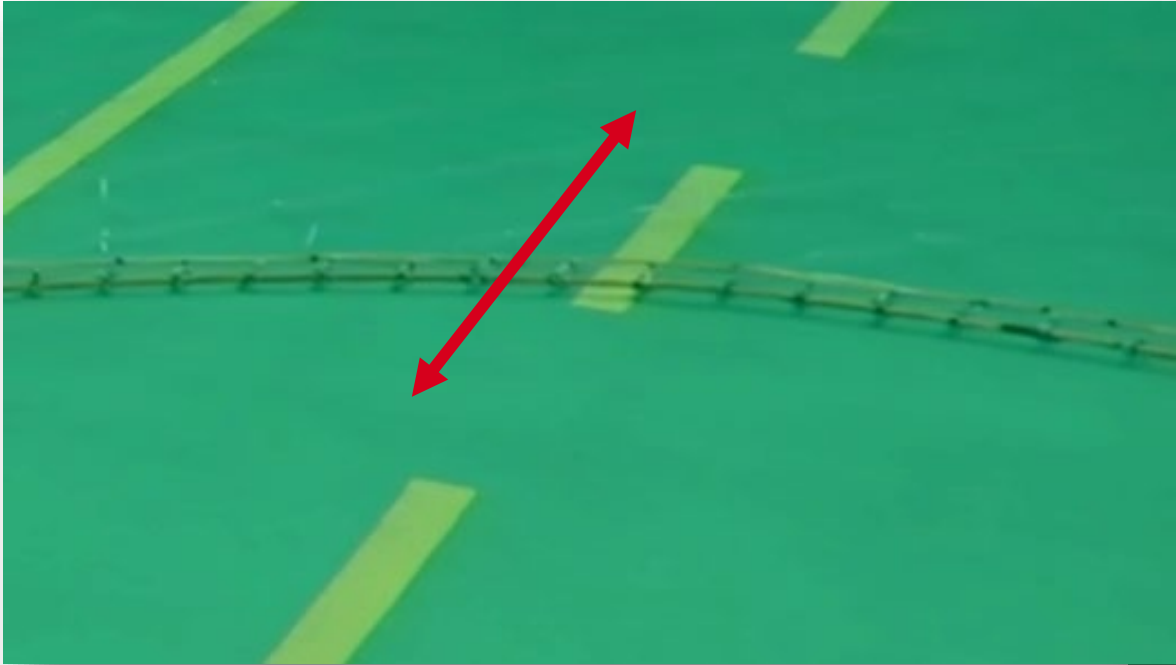

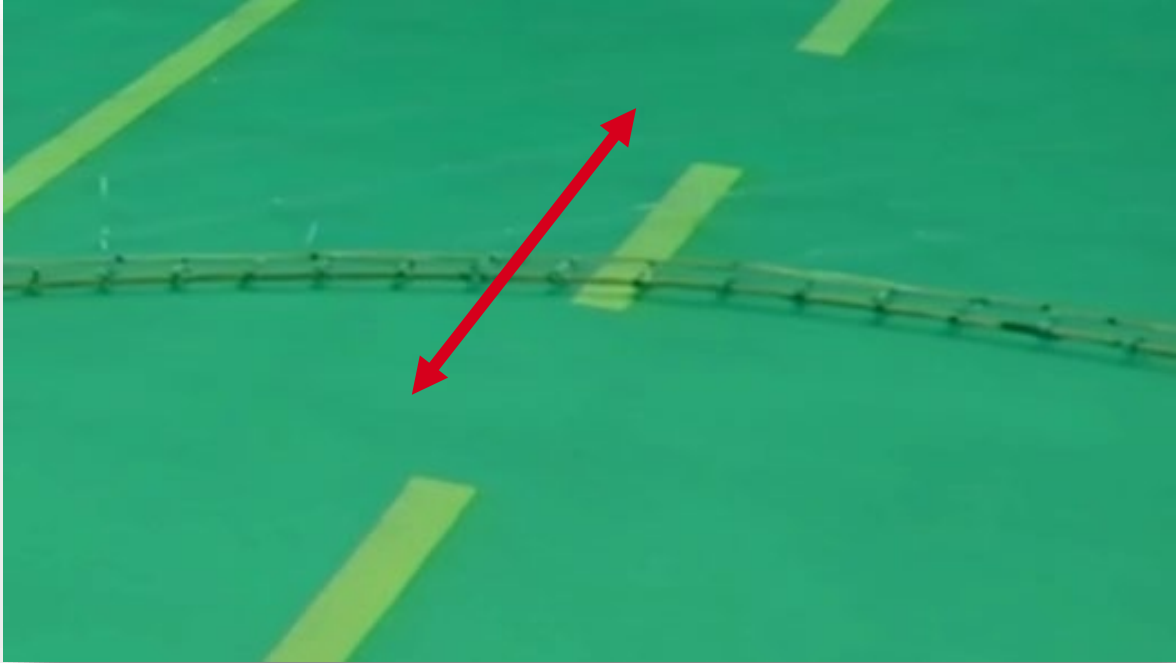

S.P.F. Development Timeline



- **Other**
 - Finish publication with Seamus Melly
 - Integrate with the Gear Innovation Initiative model (APU FAST lab) to estimate contact
 - Continue to evaluate and improve the design with Swan Net (track international developments)



Thank you